

INSTALLATION MANUAL

FERRUPS

0800-2000 - 0800-7500

FERRUPS[®] Installation Manual

0800-2000 through 0800-7500
2 kVA-7.5 kVA 50 and 60 Hz
Uninterruptible Power Systems

**IMPORTANT SAFETY INSTRUCTIONS.
SAVE THESE INSTRUCTIONS.**

This manual contains important instructions for your UPS.

Introduction

This manual is for the types of models listed below.

- All models that do not have a power cord and input plug or that do not have output receptacles. A qualified electrician must install the AC wiring for these models and connect your protected equipment. Sections [200](#), [300](#), and [500](#) of this manual describe the AC wiring and phase check.
- All models that have a separate battery cabinet. [Section 300](#) describes battery installation.

The installation and use of this product must comply with all national, federal, state, municipal, or local codes that apply. If you need help, please call the nearest Best Power office.

Best Power
P.O. Box 280
Necedah, WI 54646 U.S.A.
Telephone: 1-608-565-7200
Toll-Free: 1-800-356-5794 (U.S.A. and Canada)
FAX: 1-608-565-2221
International FAX: 1-608-565-7675

Worldwide Service
P.O. Box 11
Necedah, WI 54646 U.S.A.
Telephone: 1-608-565-2100
Toll-Free: 1-800-356-5737 (U.S.A. and Canada)
FAX: 1-608-565-7642

Best Power Technology Mexico, S.A. de C.V.
Golfo de Riga, 34
Colonia Tacuba
Mexico D.F. 11410
MEXICO
Telephone: (52) 5-399-0369
FAX: (52) 5-399-1320

Best Power Technology Pte. Ltd.
30 Prinsep St. #07-00
LKN Prinsep House
SINGAPORE 188647
Telephone: (65) 430-6168
FAX: (65) 430-6170

Sola Australia Ltd.
13 Healey Road
Dandenong, Victoria 3175
AUSTRALIA
Telephone: (61) 3-9706-5022
FAX: (61) 3-9794-9150

Best Power Technology Limited
BEST House
Wykeham Industrial Estate
Moorside Road
Winchester
Hampshire
S023 7RX
ENGLAND
Telephone: (44) 1962-844414
Toll-Free: 0800 378444
FAX: (44) 1962-841846

Best Power Technology GmbH
Am Weichselgarten 23
D-91058 Erlangen
Telephone: (49) 9131-77700
Toll-Free: 0130-84-7712 (in Germany)
FAX: (49) 9131-7770-444

Borri Elettronica Industriale Srl
Via dei Lavoratori, 124
20092 Cinisello Balsamo (Mi)
Milan, ITALY
Telephone: (39) 2-6600661-2
FAX: (39) 2-6122481

Best Power Technology AG
Limmatstrasse 12
8957 Spreitenbach
SWITZERLAND
Telephone: (41) 56-418-30-30
FAX: (41) 56-418-30-33

Best Power
82 Avenue des Martyrs
38000 Grenoble
FRANCE
Telephone: (33) (0) 4-76-86-50-90
FAX: (33) (0) 4-76-86-00-57

Contents

| | |
|---|----|
| 100 Before Installing the UPS | 4 |
| 101 Dimensions | 4 |
| 102 Installation and Service Clearances | 5 |
| 103 Location Requirements | 5 |
| 104 Receiving and Moving the FERRUPS and Battery Cabinets | 5 |
| 105 Storage and Operating Environment | 5 |
| 106 Bypass Switches | 6 |
| | |
| 200 Overview of UPS Installation | 7 |
| | |
| 300 AC Installation of the UPS and Bypass Switch (for Qualified Personnel Only) | 8 |
| 301 Starting AC Installation | 8 |
| 302 Installing Models with External Bypass Switches | 12 |
| 303 Installing Models with Internal (Attached) Bypass Switches | 20 |
| | |
| 400 Connecting the External Battery Cabinets | 24 |
| 401 Important Notices | 24 |
| 402 Tools Needed | 24 |
| 403 Safety Information | 24 |
| 404 Connecting the Battery Cabinet(s) | 25 |
| 405 Turning the DC Switch On and Off | 27 |
| | |
| 500 Parameters and Phase Check (for Qualified Personnel Only) | 27 |
| | |
| Appendix A: Connections for the Emergency Power Off (EPO) Signal | 31 |

100 Before Installing the UPS

101 Dimensions

Table 1: 2 kVA to 7.5 kVA Dimensions

| Model | Height (A) | Width (B) | Depth (C) | Depth with Internal (Attached) Bypass |
|---------------|---------------------|--------------------|----------------------|---------------------------------------|
| 2 and 3 kVA | 27.25 in. 695 mm | 13.5 in. 345 mm | 28.5 in.* 725 mm* | 35 in. 890 mm |
| 4.5 kVA | 30.5 in. 775 mm | 13.5 in. 345 mm | 25 in.* 635 mm* | 31.5 in. 800 mm |
| 6 and 7.5 kVA | 38.75 in. 985 mm | 13.5 in. 345 mm | 32.5 in.* 825 mm* | 39 in. 990 mm |

* For units with separate battery cabinets, add the depth of the battery connection box, 2.6 inches.

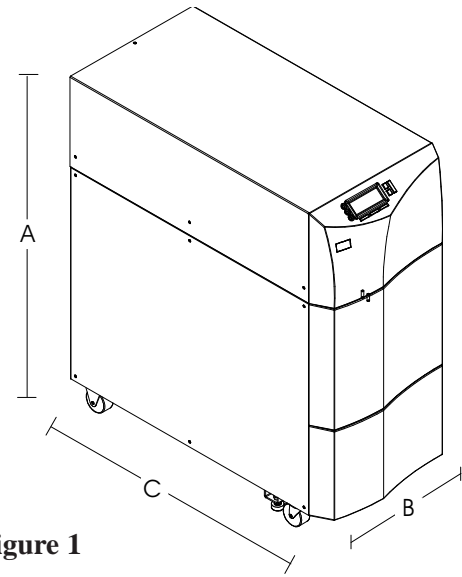

Figure 1

Table 2: Battery Cabinet Dimensions

| Model | Height (A) | Width (B) | Depth (C) |
|-------------------------|---------------------|--------------------|----------------------|
| FBT20 FBT21 FBT22 | 27.25 in. 695 mm | 13.5 in. 345 mm | 28.5 in.* 725 mm* |
| FBT30 FBT31 FBT32 | 38.75 in. 985 mm | 13.5 in. 345 mm | 32.5 in.* 825 mm* |

* Add the depth of the battery connection box, 2.6 inches.

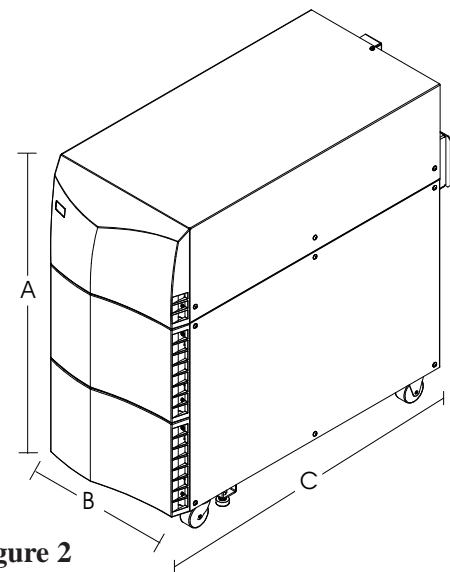

Figure 2

Table 3: Bypass Switch Dimensions

| BPE12 | | | | |
|------------------|------------------|--------------------|------------------|------------------|
| A | B | C | D | E |
| 21 in. 534 mm | 14 in. 356 mm | 6.75 in. 172 mm | 11 in. 280 mm | 20 in. 508 mm |
| BPE14 | | | | |
| A | B | C | D | E |
| 21 in. 534 mm | 14 in. 356 mm | 6.75 in. 172 mm | 11 in. 280 mm | 20 in. 508 mm |

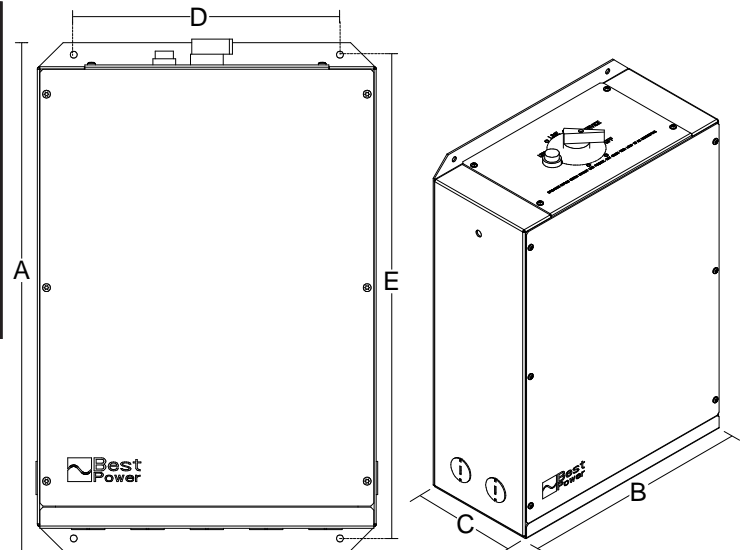

Figure 3

102 Installation and Service Clearances

Table 4: Service Clearances for FERRUPS and Battery Cabinets

| Sides (A) | Front (B) | Top (C) | Back (D) |
|------------------|------------------|------------------|------------------|
| 12 in. 305 mm | 36 in. 915 mm | 36 in. 915 mm | 12 in. 305 mm |

Note: If you use flexible conduit to connect the UPS and battery cabinets, you may be able to achieve the service clearances by moving the UPS. If this is the case, you must still leave 12 inches (305 mm) clearance at the front and back of the UPS for ventilation. **Do not block the ventilation holes on each side of the front panel.**

Figure 4

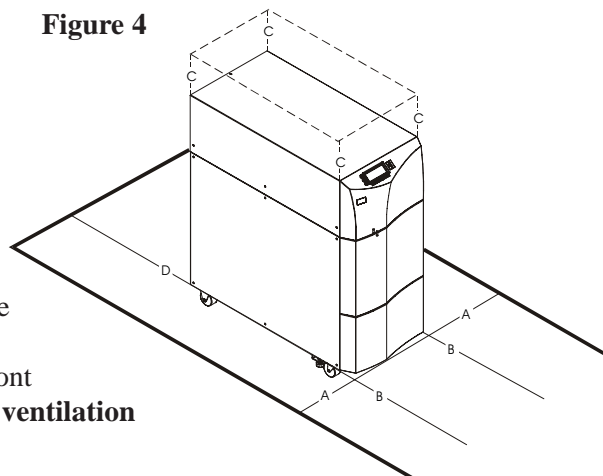

103 Location Requirements

- Install the FERRUPS as close as possible to the equipment it will protect. If this distance is more than 25 feet (7.6 meters), transient noise can reappear in the electrical distribution system.
- If the FERRUPS batteries are in a separate cabinet, the battery cabinet should be as close to the FERRUPS as possible. If the batteries will be farther away from the unit than the standard cables allow, call the nearest Best Power office for assistance.

104 Receiving and Moving the FERRUPS and the Batteries

Note the FERRUPS and battery cabinet weights in the User Manual. Before you unload or move the FERRUPS or the battery cabinet, make sure your method of moving them is appropriate for their weights.

105 Storage and Operating Environment

- Storage Temperature:* Store a FERRUPS with internal batteries or a battery cabinet at -20° to $+40^{\circ}$ Celsius (-4° to $+104^{\circ}$ F). Batteries will have a longer shelf life if you store them below 25° C (77° F). A UPS without internal batteries may be stored at -20° to $+60^{\circ}$ Celsius (-4° to $+140^{\circ}$ F).
- Operating Temperature:* 0° to 40° Celsius (32° to 104° F), up to 95% relative humidity without condensation. The batteries last longer if the operating temperature stays below 25° C (77° F).
- Ventilation:* The air around the UPS must be clean, dust-free, and free of corrosive chemicals or other contaminants. The air must be free to circulate around the UPS cabinet and any battery cabinets. **Do not place the UPS or batteries in a sealed room or container.**
- High Altitude Operation:* The maximum operating temperature drops 1° Celsius per 300 meters above sea level (2° F per 1000 feet above sea level). Maximum elevation is 3000 meters (10,000 feet).

106 Bypass Switches

If your FERRUPS model does not have a power cord and plug, you should have a Best Power bypass switch. The cabinet for these switches may be separate (external) or attached to the back of the UPS (internal).

The bypass switch has four positions (see Table 5 below). **In the UPS or LINE positions, AC input power is still connected to the input terminals inside the UPS once it is installed.** To disconnect AC input power during maintenance or service, turn the bypass switch to SERVICE. For Make-Before-Break switches, please note that you must press the red button before you can change the switch position.

Table 5: Bypass Switch Positions

| Switch Position | Explanation |
|-----------------|---|
| LINE | Connects the loads (protected equipment) directly to AC line input and disconnects UPS output. AC line input is still connected to the UPS itself. |
| OFF | Disconnects the protected equipment from both UPS output power and AC input power. |
| UPS | Connects the UPS output to the protected equipment. |
| SERVICE | Like the LINE position, SERVICE connects the loads (protected equipment) directly to AC line input and disconnects UPS output. However, since SERVICE also disconnects AC input, this is the appropriate switch position during UPS maintenance or repair. |

Bypass switches may be Make-Before-Break (MBB) or Break-Before-Make (BBM).

Make-Before-Break switches make a new connection before they break the present connection. For example, if you turned the switch from “UPS” to “LINE,” the bypass switch would connect your protected equipment to AC input power before disconnecting the equipment from UPS output power. Make-Before-Break switches are not for use with 208 VAC.

Break-Before-Make switches break the present connection before they make a new one. If you turned a Break-Before-Make switch from “UPS” to “LINE,” the switch would disconnect your protected equipment from UPS output power before connecting the equipment to AC input power.

Bypass switches come in four models, and each model has its own ratings for current and voltage. Table 6 below lists the ratings and weights for Best Power bypass switches.

Table 6: Bypass Switch Ratings and Weights

| Bypass Switch Model | Ratings, Continuous | Weight (lbs/kg) |
|---|--|-------------------|
| BPE12 (External Bypass Switch) | 40A/300VAC (CSA) 50A/300VAC (UL, TÜV) | 27 lbs. / 12.3 kg |
| BPE14 (External) | 80A/300VAC | 31 lbs. / 14.1 kg |
| Internal Bypass Switch for 2 kVA and 3 kVA Models | 40A/300VAC (CSA) 50A/300VAC (UL, TÜV) | |
| Internal Bypass Switch for 4.5, 6 and 7.5 kVA Models | 80A/300VAC | |

200 Overview of UPS Installation

Figure 6 below shows a typical installation for FERRUPS units that do **not** have an input power cord and plug. This diagram shows a unit with a separate battery cabinet and a separate bypass switch. In units with internal bypass switches, the switch is attached to the back of the UPS, and the UPS is already wired to the switch.

Typical Installation with an External (Separate) Bypass Switch

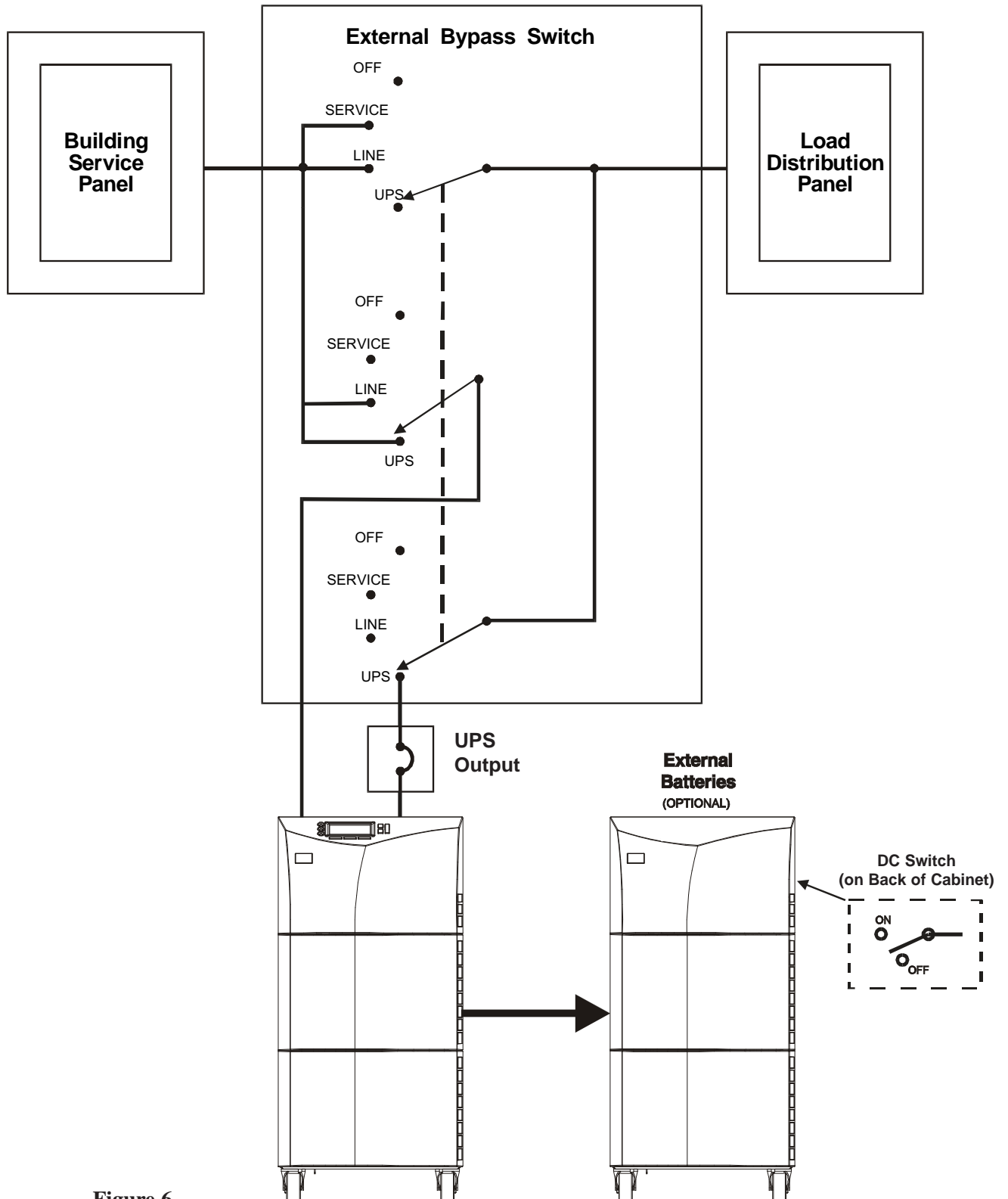

Figure 6

300 AC Installation of the UPS and Bypass Switch (for Qualified Personnel Only)

301 Starting AC Installation

 **CAUTION**

Read the cautions below before you begin AC installation:

- A. All UPS units contain hazardous AC and DC voltages. Because of this, a qualified electrician must install the UPS and AC line service. The electrician must install AC line according to local and national codes.
- B. This equipment relies on protection devices in the building installation. These devices must be installed within sight of the UPS.
- C. Before you install, maintain, or service the UPS, always remove or shut off all sources of AC and DC power and shut off the UPS. You must disconnect AC line input at the service panel, turn the DC switch OFF and shut the UPS down to make sure it will not supply output voltage.
- D. Whenever AC and/or DC voltage is applied, there may be AC voltage at the UPS terminals; this is true because the UPS can supply power from AC input or from its batteries. To avoid equipment damage or personal injury, always assume that there may be voltage at the UPS terminals.
- E. Before you install the bypass switch, make sure that the bypass switch is OFF.
- F. To reduce the risk of fire or electric shock, install the FERRUPS and the batteries in a temperature-controlled and humidity-controlled indoor area free of conductive contaminants. See [Section 105](#) for operating environment specifications.

1. Find the FERRUPS ID label on the back panel, and note the following:

Model Number: _____ Input Voltage: _____ Output Voltage: _____

2. Next, find the bypass switch's ID label, and write down the following:

Model Number: _____ Make-Before-Break (MBB) or Break-Before-Make (BBM)? _____
External (Separate) or Internal (Attached)? _____

3. Now, answer the questions below. **Remember that the FERRUPS provides single-phase power only.**

- a. Does the input voltage at the AC service panel match the input voltage on the UPS ID label?

Service panel voltage: _____ = UPS Input Voltage: _____ Yes No

- b. Does the output voltage on the UPS ID label match the voltage your loads (protected equipment) will need?

Load voltage: _____ = UPS Output Voltage: _____ Yes No

If the answer to either a. or b. is No, call the nearest Best Power office for assistance.

4. Now use the information you wrote down in steps 1-3 to find the Installation Wiring Diagram that applies to your FERRUPS installation. If the bypass switch is external (separate), use Table 7. If it is internal (attached), use Table 8.

Table 7: Installation Wiring Diagrams for Units with External Bypass Switches

| Input and Output VAC | Bypass Switch Type | Use These Diagrams: |
|--|--|---------------------------------|
| 120 input and 120 output | Make-Before-Break or Break-Before-Make | Figure 10 and Figure 13A |
| 127 input and 127 output | Break-Before-Make only. | Figure 10 and Figure 13C |
| 220 input and 220 output (except Mexico) | Make-Before-Break or Break-Before-Make | Figure 10 and Figure 13D or 13F |
| 230 input and 230 output | Make-Before-Break or Break-Before-Make | Figure 10 and Figure 13E or 13G |
| 240 input and 240 output | Make-Before-Break or Break-Before-Make | Figure 10 and Figure 13A or 13H |
| 208 input and 208 or 240 output | Break-Before-Make only. | Figure 11 and Figure 13B |
| 208 input and 120/208 output | Break-Before-Make only. | Figure 11 and Figure 13B |
| 208 input and 120/240 output | Break-Before-Make only. | Figure 11 and Figure 13A |
| 220 input and 220 output (Mexico) | Make-Before-Break or Break-Before-Make | Figure 11 and Figure 13C |
| 220 input and 220 output | Make-Before-Break or Break-Before-Make | Figure 11 and Figure 13D |
| 220 input and 127 output** | Break-Before-Make only. | Call Best Power.** |
| 230 input and 230 output | Make-Before-Break or Break-Before-Make | Figure 11 and Figure 13E |
| 240 input and 208 output** | Break-Before-Make only. | Call Best Power.** |
| 240 input and 120/240 output | Make-Before-Break or Break-Before-Make | Figure 11 and Figure 13A |
| 208 or 480 Source*/ 240 Input | Make-Before-Break or Break-Before-Make | Figure 12 and Figure 13A |

* With a step-up or step-down transformer.

** Call Best Power for a) single-phase installations that do not have the same input and output voltage, or b) split-phase installations that require 220 or 127 VAC.

Table 8: Installation Wiring Diagrams for Units with Internal Bypass Switches

| Input and Output VAC | Bypass Switch Type | Use This Diagram: |
|---|---|--------------------|
| 120 input and 120 output 127 input and 127 output 220 input and 220 output (except Mexico) 230 input and 230 output 240 input and 240 output | Make-Before-Break or Break-Before-Make For 127 VAC, Break-Before-Make only. | Figure 15 |
| 208 input and 208 output 208 input and 120/208 output 208 input and 120/240 output 220 input and 220 output (Mexico) 230 input and 230 output 240 input and 120/240 output | Make-Before-Break or Break-Before-Make For 208 VAC, Break-Before-Make only. | Figure 16 |
| 220 input and 127 output** 240 input and 208 output** | Break-Before-Make only. | Call Best Power.** |
| 208 or 480 Source*/ 240 Input | Make-Before-Break or Break-Before-Make | Figure 17 |

* With a step-up or step-down transformer.

** Call Best Power for a) single-phase installations that do not have the same input and output voltage, or b) split-phase installations that require 220 or 127 VAC.

5. Now, refer to the wiring diagram that you selected in step 3, and use Tables 9 and 10 below to find the proper size circuit breaker for your installation. Table 9 shows the required input circuit breaker size for U.S. installations. Table 10 shows the input current for each voltage; size input overcurrent protection according to local codes. In the U.S., use the circuit breaker size and [Table 11](#) to size the wiring. In other areas, size wiring according to local code, **making sure you use 75° C copper wire.**

Table 9: Required Input Circuit Breaker Sizes for U.S. Installations (60 Hz)

| UPS Model | 120V | 208V | 240V |
|-----------|--------|--------|--------|
| 2 kVA | 30-amp | 15-amp | 15-amp |
| 3 kVA | 40-amp | 20-amp | 20-amp |
| 4.5 kVA | 50-amp | 25-amp | 25-amp |
| 6 kVA | | 35-amp | 35-amp |
| 7.5 kVA | | 45-amp | 45-amp |

Table 10: Input Current (Size input overcurrent protection according to local codes.)

| UPS Model | Frequency | 110V | 115V | 120V | 127V | 208V | 220V | 230V | 240V |
|-----------|-----------|---------|---------|---------|---------|---------|---------|---------|---------|
| 2 kVA | 60 Hz | 22 amps | 22 amps | 22 amps | 22 amps | 12 amps | 12 amps | 12 amps | 12 amps |
| | 50 Hz | 22 amps | 22 amps | 22 amps | 22 amps | 12 amps | 12 amps | 12 amps | 12 amps |
| 3 kVA | 60 Hz | 30 amps | 30 amps | 30 amps | 30 amps | 16 amps | 16 amps | 16 amps | 16 amps |
| | 50 Hz | 30 amps | 30 amps | 30 amps | 30 amps | 16 amps | 16 amps | 16 amps | 16 amps |
| 4.5 kVA | 60 Hz | 40 amps | 40 amps | 40 amps | 40 amps | 20 amps | 20 amps | 20 amps | 20 amps |
| | 50 Hz | 40 amps | 40 amps | 40 amps | 40 amps | 20 amps | 20 amps | 20 amps | 20 amps |
| 6 kVA | 60 Hz | | | | | 28 amps | 28 amps | 28 amps | 28 amps |
| | 50 Hz | | | | | 28 amps | 28 amps | 28 amps | 28 amps |
| 7.5 kVA | 60 Hz | | | | | 36 amps | 36 amps | 36 amps | 36 amps |

Table 11: United States Recommended AWG and mm² Wire Sizes

| | | | |
|--|--|---|------------------------------|
| <p>For U.S. installations, read this Important Note!</p> <p>This table lists the AWG and mm² wire size for each circuit breaker size shown on the wiring diagrams. The minimum recommended circuit breaker sizes for each model and voltage application are listed on the wiring diagrams.</p> <p>The conductor size shall be no smaller than the 75° C wire size based on the ampacities given in Tables 310-316 of the National Electrical Code, ANSI/NFPA 70-1993, and article 220. All circuit conductors, including the neutral and equipment grounding conductors, must be the same size (ampacity) wire. Code may require a larger AWG size than shown in this table because of temperature, number of conductors in the conduit, or long service runs. Follow local code requirements.</p> | <p>For this Input Circuit Breaker Size...</p> | <p>Use this Size 75° C Copper Wire</p> | |
| | | <p>AWG</p> | <p>mm²</p> |
| | 15, 20 | 12 | 3.31 |
| | 25, 30 | 10 | 5.26 |
| | 35, 40, 45, 50 | 8 | 8.36 |
| | 60 | 6 | 13.30 |
| | 70, 80 | 4 | 21.15 |
| | 90, 100 | 3 | 26.67 |
| | 110 | 2 | 33.62 |
| | 125 | 1 | 42.11 |
| 150 | 1/0 | 53.49 | |

- Size the UPS output overcurrent protection device (fuse or circuit breaker) according to local code requirements. Do not exceed the ratings in Table 12. The table below shows the maximum permitted overcurrent protection device ratings; these are also the ratings recommended for U.S. applications.

Table 12: Maximum Permitted UPS Output Overcurrent Protection Device Rating

| UPS Model | 120/208 | 120 and/or 240 | 127 only | 127/220 | 208 only | 220 | 230 |
|-----------|-----------|----------------|----------|-----------|----------|------|------|
| 2 kVA | 25 / 15 A | 25 / 15 A | 16 A | 16 / 10 A | 15 A | 10 A | 9 A |
| 3 kVA | 35 / 20 A | 35 / 20 A | 24 A | 24 / 14 A | 20 A | 14 A | 14 A |
| 4.5 kVA | 50 / 30 A | 50 / 25 A | 36 A | 36 / 21 A | 30 A | 21 A | 20 A |
| 6 kVA | 70 / 40 A | 70 / 35 A | 48 A | 48 / 28 A | 40 A | 28 A | 27 A |
| 7.5 kVA | 80 / 45 A | 80 / 40 A | 60 A | 60 / 35 A | 45 A | 35 A | 33 A |

- If your model has an **external** bypass switch, go on to [Section 302](#) below. If your model has an **internal** (attached) bypass switch, go to [Section 303](#) on page 20.

302 Installing Models with External Bypass Switches

1. Mount the bypass switch within sight of the UPS. If you do not have a Best Power bypass switch, or if the fuse box or panel is out of sight, you must install a separate disconnect switch next to the UPS.
2. Remove the six screws in the bypass switch front panel and remove the panel. Remove the foam packing material that is inside the bypass switch. Then, remove knockouts in the bottom of the bypass switch for AC Line Input, AC to UPS Input, AC from UPS Output, and AC to the UPS-protected equipment (loads).
3. Next, remove the top portion of the UPS cover.

CAUTION

To prevent electrical shock or damage to your equipment, make sure the FERRUPS is OFF before you remove the cover. The circuit breaker or disconnect switch must also be off at the AC input service panel.

To remove the top UPS cover, first pull the top front panel out slightly until it clicks once; the holes in the right side of the panel can help you do this. **Do not strain the ribbon cable behind this panel.** If you need to remove the panel completely, you can disconnect the ribbon cable, but the display will not operate until you reconnect it. Remove the three screws on each side of the UPS and one screw on the top of the UPS (toward the back). Then, lift the cover off the UPS. See Figure 7.

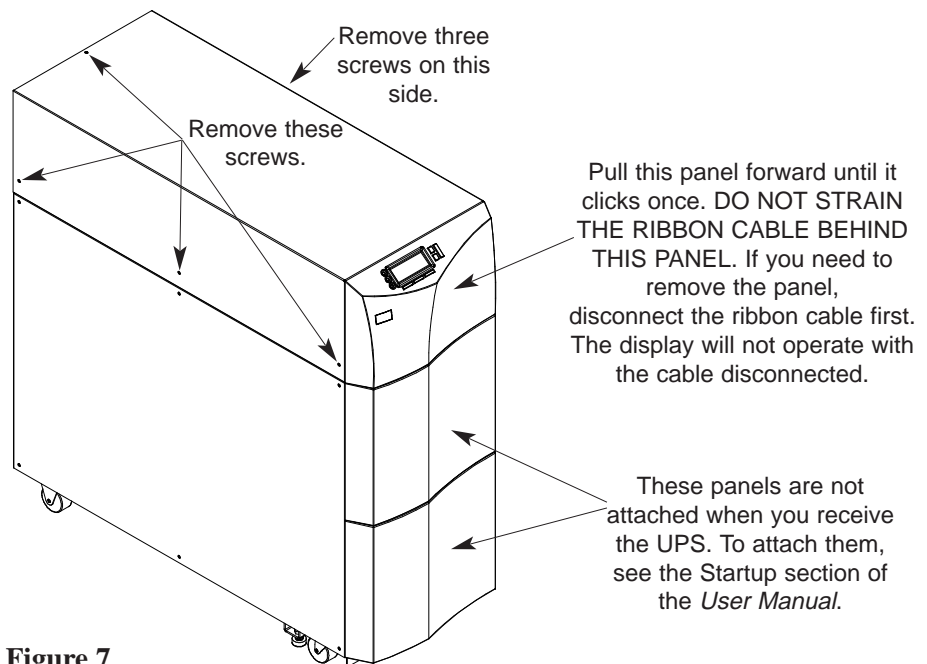

Figure 7

4. Remove the knockouts in the FERRUPS back panel for AC Input and AC Output.
5. Install the conduit adapters. AC Input and AC Output conductors must be run through separate conduit. UPS output circuits shall be installed in dedicated conduit systems and not shared with other electrical circuits.

CAUTION

To prevent electrical shock or damage to your equipment, make sure the AC input is OFF at the service panel and the bypass and AC Disconnect switches are OFF before you connect any wires to the bypass switch terminal strip.

6. Find the terminal strip inside the bypass switch. Using the label on the back of the bypass switch's access panel and the Installation Wiring Diagram for your UPS, make the terminal strip connections and tighten all connections securely. Use copper wire that is the appropriate size for the current draw. See Figure 8 for a sample label.

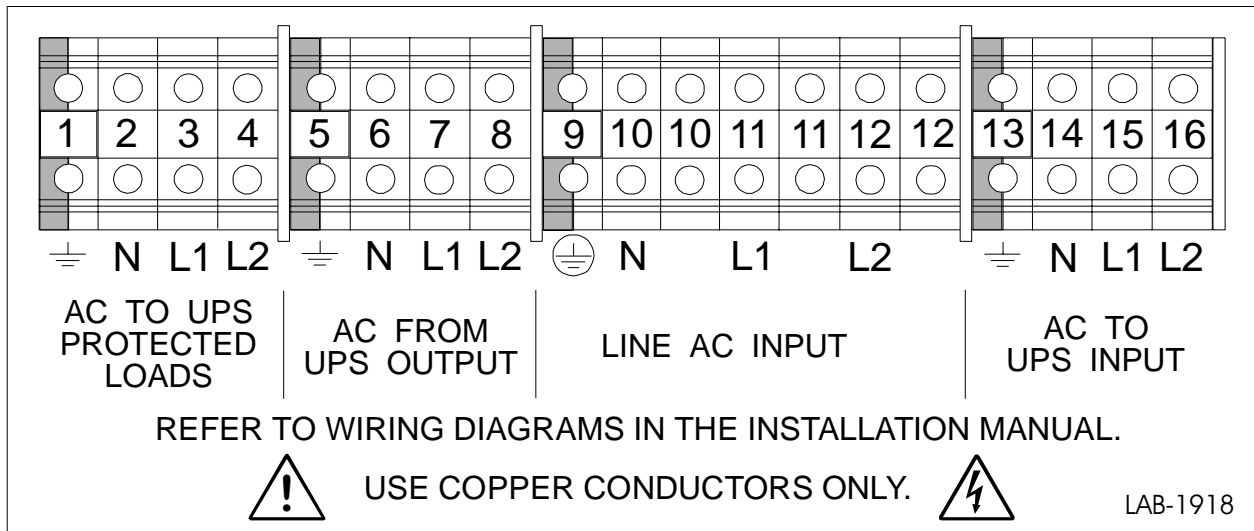

Figure 8

7. Find the proper output neutral-to-ground connection in [Figure 13](#) on pages 18-19. At the UPS terminal strip, connect the neutral-to-ground (neutral-to-earth) wire to the proper output terminal **before making any other connections to the UPS**. The neutral-to-ground wire is a green and yellow wire labeled WIA-0424. One end of this wire is already connected to ground (earth) on the UPS terminal strip.
8. Notice that there is a cable routed out of the left side of the bypass switch cabinet. The wires in this cable must be connected to the UPS logic board to provide bypass status signals to the UPS. To connect the wires, follow the steps below. If you plan to use the Emergency Power Off feature, see [Appendix A](#).

a) Route the wires through the UPS grommet shown below and to connector J13 on the logic board.

b) Pull the 8-pin connector at J13 apart as shown. The portion you remove from the connector has 8 possible connection points.

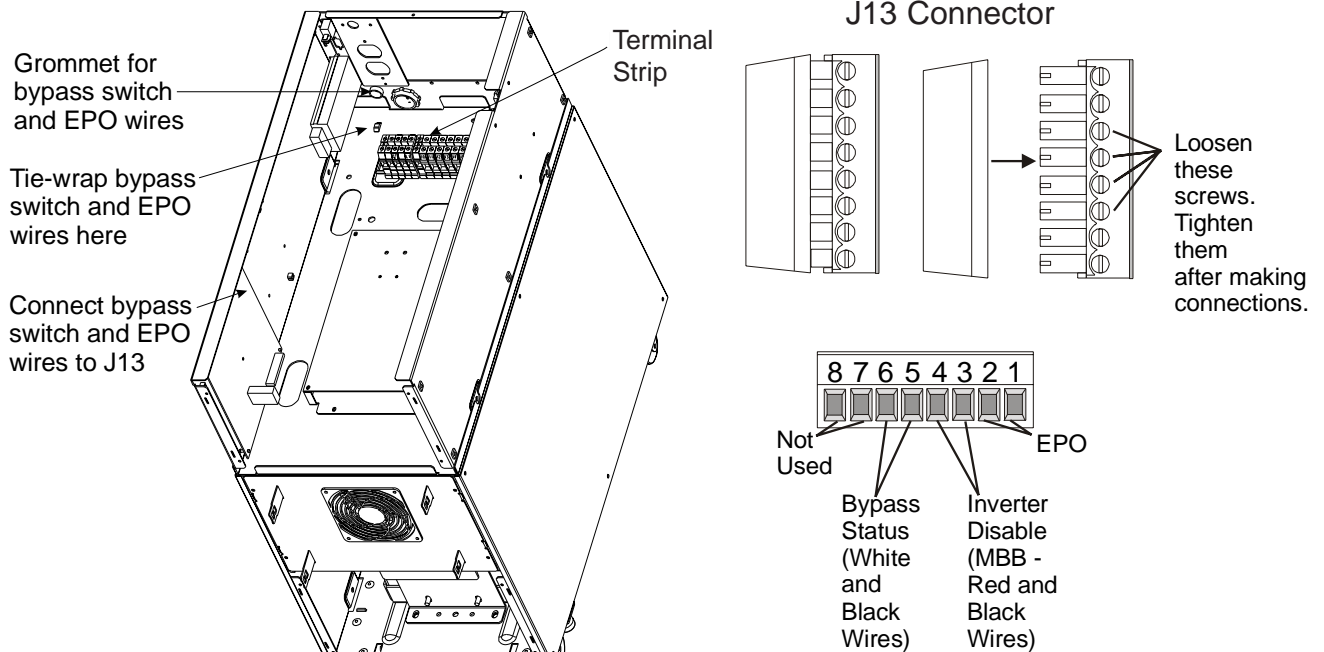

Figure 9

- c) Loosen the standard screws on the J13 connector as shown in [Figure 9](#).
- d) If your bypass switch is Make-Before-Break (MBB), connect the red and black pair of wires to the terminals marked 3 and 4 in Figure 9, with the red wire going to 3 and the black wire going to 4.
- e) For all external bypass switches, connect the white and black pair of wires to 5 and 6, with the white wire going to 5 and the black wire going to 6.

Note: If you need to make a connection for an Emergency Power Off signal, complete the steps in [Appendix A](#) before you go on.

- f) Tighten the screws to secure the connections (torque specification is 2.61 inch-pounds/0.3 N-m), and reattach the connector to J13 on the logic board.

- g) Use the tie-wraps provided to secure the cable. See Figure 9.

9. Using the Installation Wiring Diagram (Figure [10](#), [11](#), or [12](#)) for your UPS, make the UPS terminal strip connections and complete the AC installation wiring. **Read the notes with each diagram carefully.** See [Figure 13](#) for UPS terminations.

Make all connections exactly as shown on the Installation Wiring Diagram to make sure the phasing is correct. Good ground connections are necessary to reduce electrical noise and make UPS and load operation safe. Follow the grounding guidelines on the installation wiring diagram.

Torque for these connections should be 10.6-12.3 inch-pounds (1.2-1.4 Newton-meters).

10. If your UPS has one or more separate battery cabinets, go on to [Section 400](#) to install them. If not, go to [Section 500](#) to set UPS parameters and perform the phase check.

Figure 10: Installation Wiring Diagram for 2, 3, 4.5, 6, and 7.5 kVA FERRUPS Models with External Bypass Switch (L - N)

- 120 input and 120 output
- 220 input and 220 output (except Mexico)
- 240 input and 240 output
- 127 input and 127 output (Break-Before-Make only)
- 230 input and 230 output

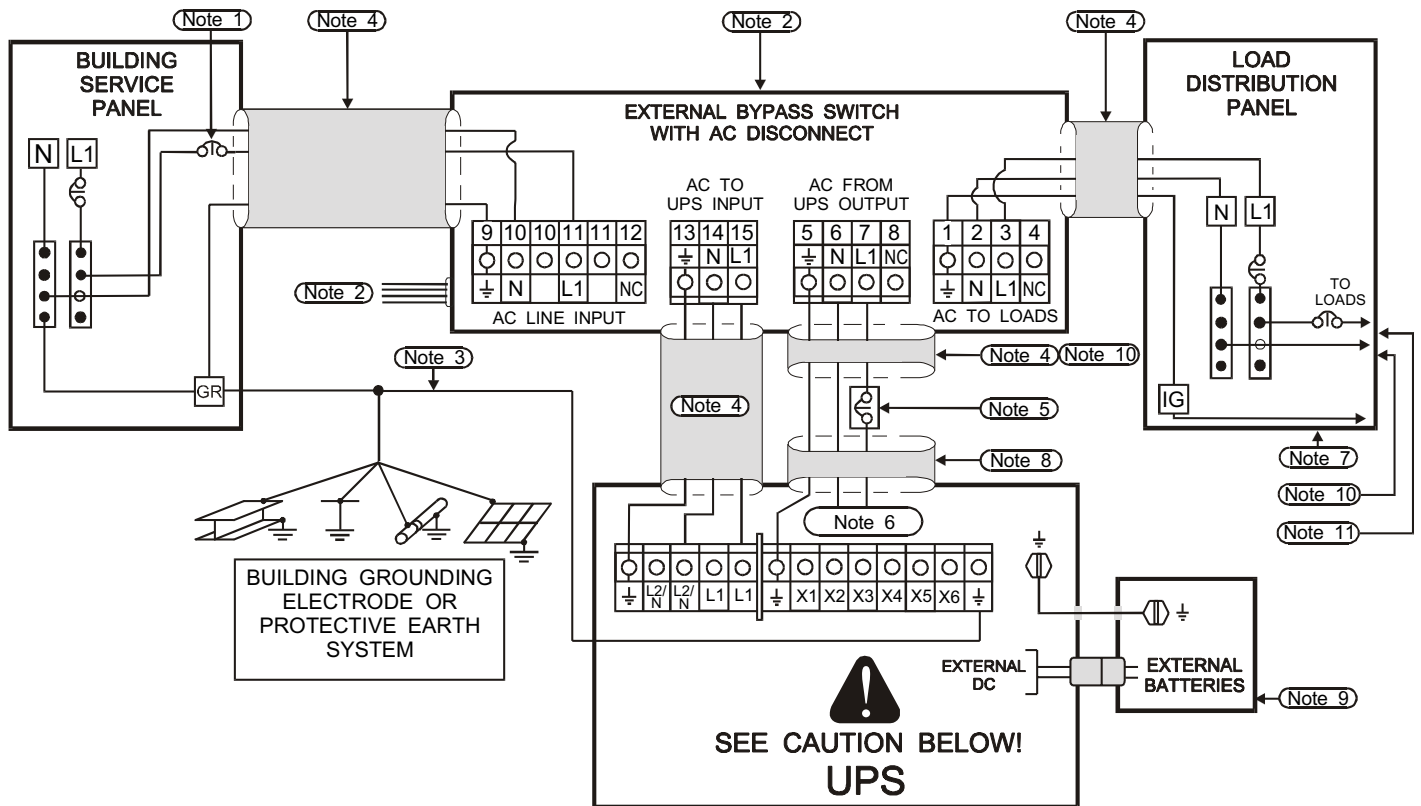

NOTE 1: The customer must provide input overcurrent protection as stated in NEC Section 240-21 or local codes. Size the protection device according to local code requirements. (See [Tables 9 and 10](#) on page 10.)

NOTE 2: The UPS bypass switch must be installed within sight of the UPS. To properly install, complete the voltage and phase check procedure in [Section 500](#). **The wires coming from the side of the switch must be connected as described in [step 8](#) on pages 13-14.**

NOTE 3: The customer must provide and install this ground (earth) connection per NEC Sections 250-5(d), 250-26, 250-91 and 250-92, or local code requirements. This grounding electrode conductor must be at least #8 AWG (8.36 mm²) per NEC table 250-94. If the UPS input circuit conductors are larger than #8 AWG (8.36 mm²), Best Power requires the grounding electrode conductor to be the same size (ampacity) as the largest UPS input circuit conductor. See NEC Section 110-3(b). Conduit is not considered an acceptable grounding electrode conductor. Best Power does not recommend routing the grounding electrode conductor through metallic conduit. This conductor may require protection from physical damage according to local code requirements.

NOTE 4: All AC circuit conductors, including the neutral and equipment grounding conductors, must be the same size (ampacity), have the same rating (75° C copper wire), and be sized according to the input circuit breaker. The UPS input and output conductors must be run through separate conduits.

NOTE 5: The customer must provide output overcurrent protection. See NEC Section 240-21 or local requirements. See [Table 12](#) on page 11 for maximum output overcurrent protection device ratings.

NOTE 6: See [Figure 13](#) for proper output wiring termination and neutral-to-ground (neutral-to-earth) connection.

NOTE 7: For maximum protection against electrical noise, use isolated ground receptacles. See NEC Section 250-74, Exception #4.

NOTE 8: See [Section 102](#) for installation and service clearances before installing the UPS. Use flexible conduit on the UPS or the external battery cabinet if either must be moved.

NOTE 9: External UPS battery cabinets are optional. See [Section 400](#) for installation instructions.

NOTE 10: UPS output circuits shall be installed in dedicated conduit systems and not shared with other electrical circuits.

NOTE 11: The load fuse or circuit breaker should be sized to match the load current requirements. See [Table 12](#).

Figure 11: Installation Wiring Diagram for 2, 3, 4.5, 6, and 7.5 kVA FERRUPS Models with External Bypass Switch (L1, L2, N)

- 208 Input, 120/240 Output
- 208 Input, 120/208 Output
- 120 or 240 Input, 120/240 Output
- 208 Input, 208 or 240 Output
- 60 Hz 220 Input, 220 Output (Mexico)

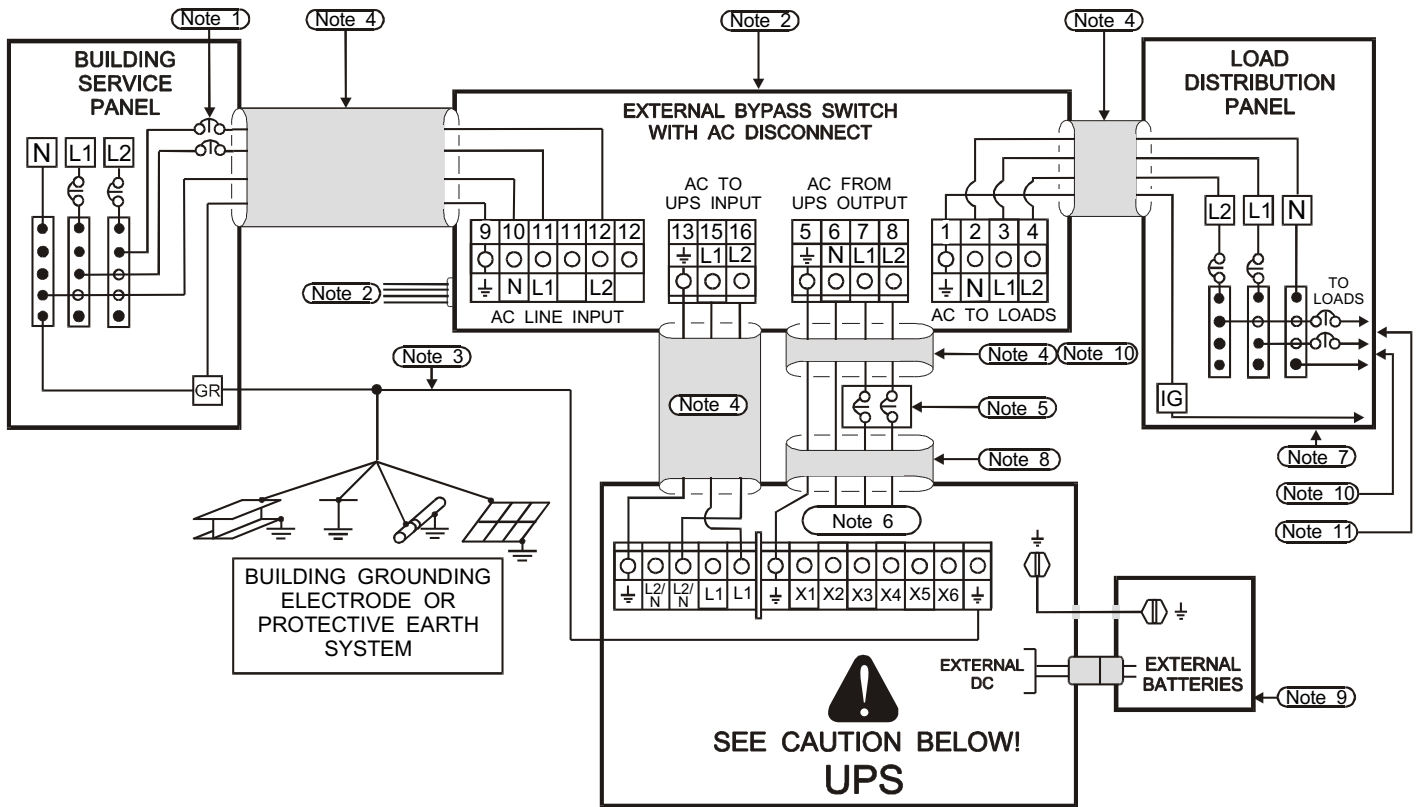

NOTE 1: The customer must provide input overcurrent protection as stated in NEC Section 240-21 or local codes. Size the protection device according to local code requirements. (See [Tables 9 and 10](#) on page 10.)

NOTE 2: The UPS bypass switch must be installed within sight of the UPS. To properly install, complete the voltage and phase check procedure in [Section 500](#). **The wires coming from the side of the switch must be connected as described in [step 8](#) on pages 13-14.**

NOTE 3: The customer must provide and install this ground (earth) connection per NEC Sections 250-5(d), 250-26, 250-91 and 250-92, or local code requirements. This grounding electrode conductor must be at least #8 AWG (8.36 mm²) per NEC table 250-94. If the UPS input circuit conductors are larger than #8 AWG (8.36 mm²), Best Power requires the grounding electrode conductor to be the same size (ampacity) as the largest UPS input circuit conductor. See NEC Section 110-3(b). Conduit is not considered an acceptable grounding electrode conductor. Best Power does not recommend routing the grounding electrode conductor through metallic conduit. This conductor may require protection from physical damage according to local code requirements.

NOTE 4: All AC circuit conductors, including the neutral and equipment grounding conductors, must be the same size (ampacity), have the same rating (75° C copper wire), and be sized according to the input circuit breaker. The UPS input and output conductors must be run through separate conduits.

NOTE 5: The customer must provide output overcurrent protection. See NEC Section 240-21 or local requirements. See [Table 12](#) on page 11 for maximum output overcurrent protection device ratings.

NOTE 6: See [Figure 13](#) for proper output wiring termination and neutral-to-ground (neutral-to-earth) connection.

NOTE 7: For maximum protection against electrical noise, use isolated ground receptacles. See NEC Section 250-74, Exception #4.

NOTE 8: See [Section 102](#) for installation and service clearances before installing the UPS. Use flexible conduit on the UPS or the external battery cabinet if either must be moved.

NOTE 9: External UPS battery cabinets are optional. See [Section 400](#) for installation instructions.

NOTE 10: UPS output circuits shall be installed in dedicated conduit systems and not shared with other electrical circuits.

NOTE 11: The load fuse or circuit breaker should be sized to match the load current requirements. See [Table 12](#).

Figure 12: Installation Wiring Diagram for 2, 3, 4.5, 6, and 7.5 kVA FERRUPS Models with External Bypass Switch (L1, L2, N)

60 Hz 208 or 480 VAC Source with Input Step-Up or Step-Down Isolation Transformer
240 UPS Input - 120/240 UPS Output

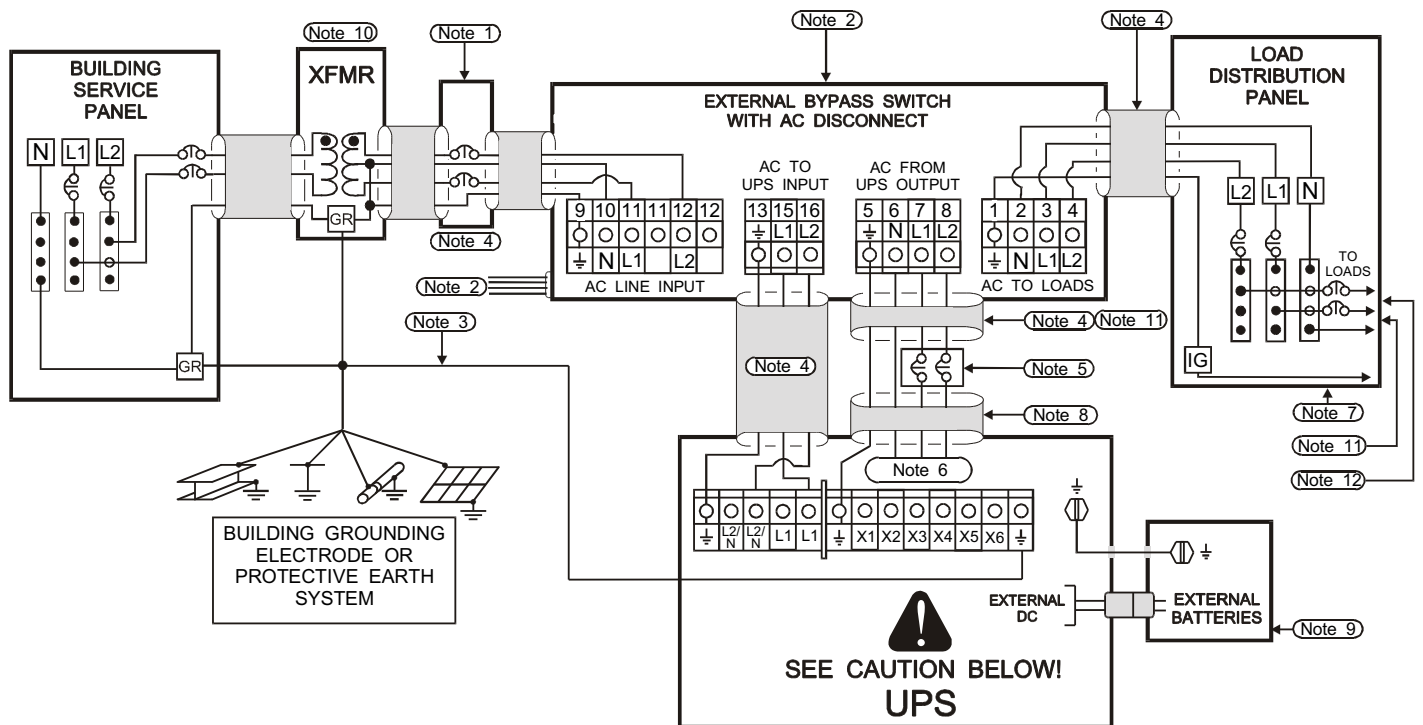

NOTE 1: The customer must provide input overcurrent protection as stated in NEC Section 240-21 or local codes. Size the protection device according to local code requirements. (See [Tables 9 and 10](#) on page 10.)

NOTE 2: The UPS bypass switch must be installed within sight of the UPS. To properly install, complete the voltage and phase check procedure in [Section 500](#). **The wires coming from the side of the switch must be connected as described in [step 8](#) on pages 13-14.**

NOTE 3: The customer must provide and install this ground (earth) connection per NEC Sections 250-5(d), 250-26, 250-91 and 250-92, or local code requirements. This grounding electrode conductor must be at least #8 AWG (8.36 mm²) per NEC table 250-94. If the UPS input circuit conductors are larger than #8 AWG (8.36 mm²), Best Power requires the grounding electrode conductor to be the same size (ampacity) as the largest UPS input circuit conductor. See NEC Section 110-3(b). Conduit is not considered an acceptable grounding electrode conductor. Best Power does not recommend routing the grounding electrode conductor through metallic conduit. This conductor may require protection from physical damage according to local code requirements.

NOTE 4: All AC circuit conductors, including the neutral and equipment grounding conductors, must be the same size (ampacity), have the same rating (75° C copper wire), and be sized according to the input circuit breaker. The UPS input and output conductors must be run through separate conduits.

NOTE 5: The customer must provide output overcurrent protection. See NEC Section 240-21 or local requirements. See [Table 12](#) on page 11 for maximum output overcurrent protection device ratings.

NOTE 6: See [Figure 13](#) for proper output wiring termination and neutral-to-ground (neutral-to-earth) connection.

NOTE 7: For maximum protection against electrical noise, use isolated ground receptacles. See NEC Section 250-74, Exception #4.

NOTE 8: See [Section 102](#) for installation and service clearances before installing the UPS. Use flexible conduit on the UPS or the external battery cabinet if either must be moved.

NOTE 9: External UPS battery cabinets are optional. See [Section 400](#) for installation instructions.

NOTE 10: For 208 VAC, use a step-up transformer. For 480 VAC, use a step-down transformer. Use an isolation transformer with a 120/240 grounded center-tapped neutral output. *Do not use a buck/boost transformer.*

NOTE 11: UPS output circuits shall be installed in dedicated conduit systems and not shared with other electrical circuits.

NOTE 12: The load fuse or circuit breaker should be sized to match the load current requirements. See [Table 12](#).

Figure 13: UPS Output Wiring Connections

Find the output wiring configuration (Figure 13A - 13H) for your UPS input voltage and frequency and UPS output voltage(s). Make the neutral-to-ground (neutral-to-earth) connection first. Then, wire the output from the UPS as shown. In [Section 500](#), you will set parameter 4 8 to the correct output voltage.

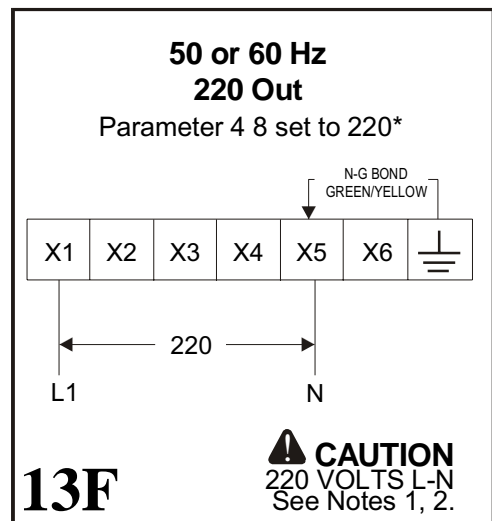
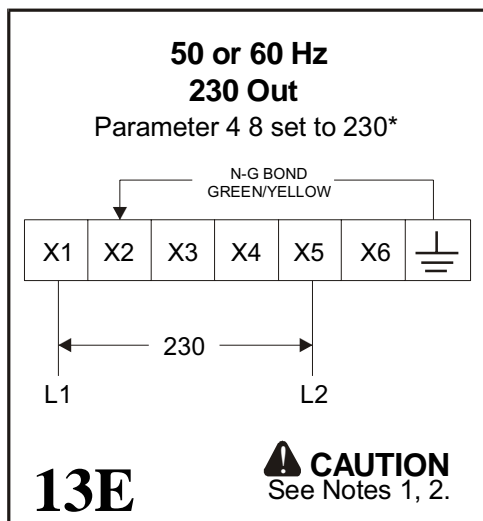
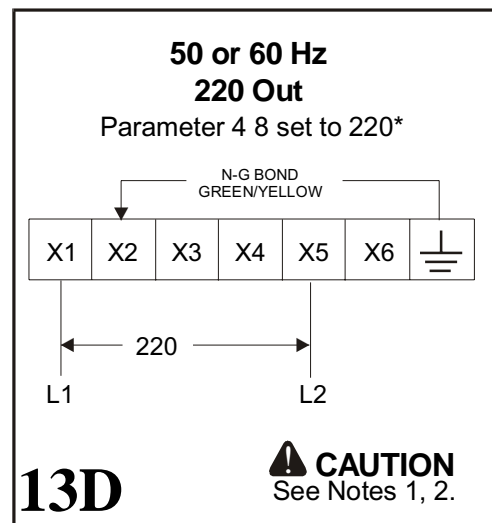
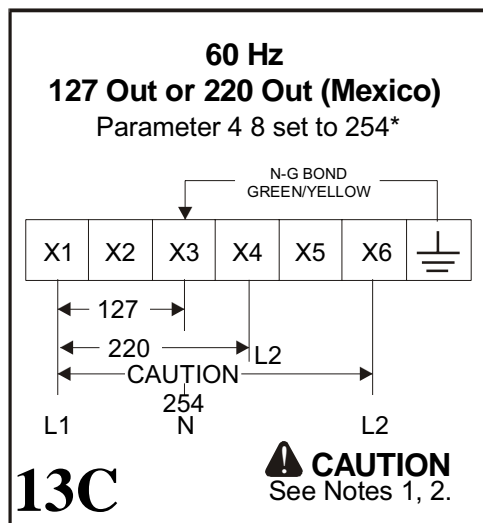
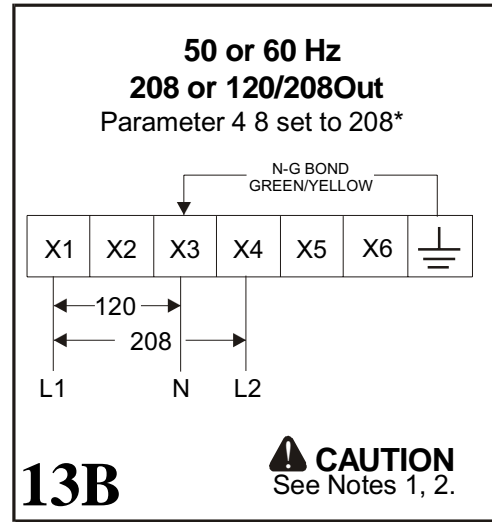
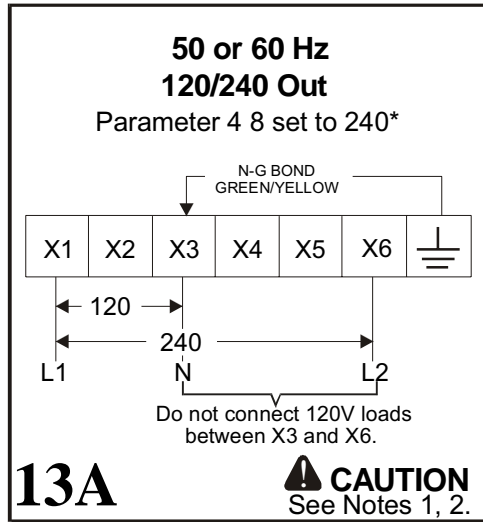

303 Installing Models with Internal (Attached) Bypass Switches

1. The internal bypass switch is attached to the back of the UPS. Remove the screws in the *lower* part of the bypass switch's back panel to remove the panel. Then, remove knock-outs in the bottom of the bypass switch for AC Line Input and AC to UPS-protected equipment (loads).
2. Install the conduit adapters. You must run the AC input service conductor and the AC Output through separate conduit adapters and separate conduit. UPS output circuits shall be installed in dedicated conduit systems and not shared with other electrical circuits.

CAUTION

To prevent electrical shock or damage to your equipment, make sure the AC input is OFF at the service panel and the bypass and AC Disconnect switches are OFF before you connect any wires to the bypass switch terminal strip.

3. Find the terminal strip inside the bypass switch. Using the label inside the switch and the appropriate Installation Wiring diagram on the following pages (Figure 15, 16, or 17), make the terminal strip connections, tightening all connections securely. Use copper wire, and use the appropriate wire size for the current draw. Figure 14 below shows a sample terminal strip label. Torque specifications for these connections are 10.6-12.3 inch-pounds (1.2-1.4 N-m).

Important: Make all terminal strip connections exactly as they are shown on the Installation Wiring Diagram to ensure correct phase relationships, and follow the grounding guidelines in the Diagram. Good ground connections are necessary to reduce electrical noise and make operation of the UPS and the loads safe.

Internal Bypass Switch Terminal Label

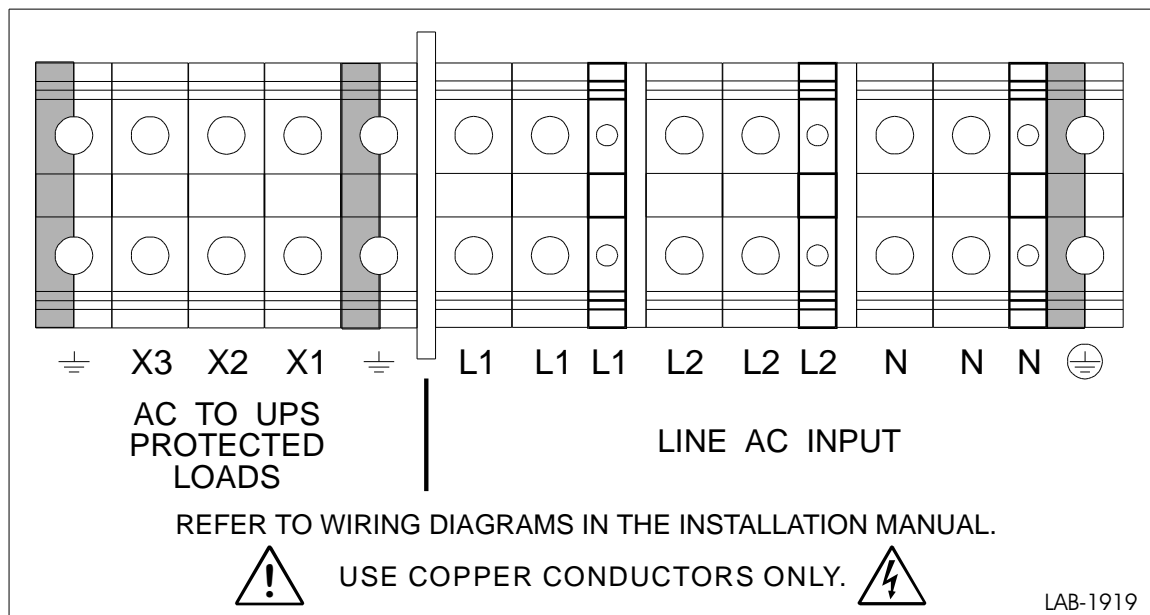

Figure 14

4. If your UPS does not have a separate battery cabinet (external batteries), go to [Section 500](#) to set UPS parameters and perform the phase check.

If your model has external batteries, go to [Section 400](#), Installing the Batteries and DC wiring. Then, go to [Section 500](#).

Figure 15: Installation Wiring Diagram for 2, 3, 4.5, 6, and 7.5 kVA FERRUPS Models with Internal Bypass Switch (L1 - N)

- 120 input and 120 output
- 220 input and 220 output (except Mexico)
- 240 input and 240 output
- 127 input and 127 output (Break-Before-Make only)
- 230 input and 230 output

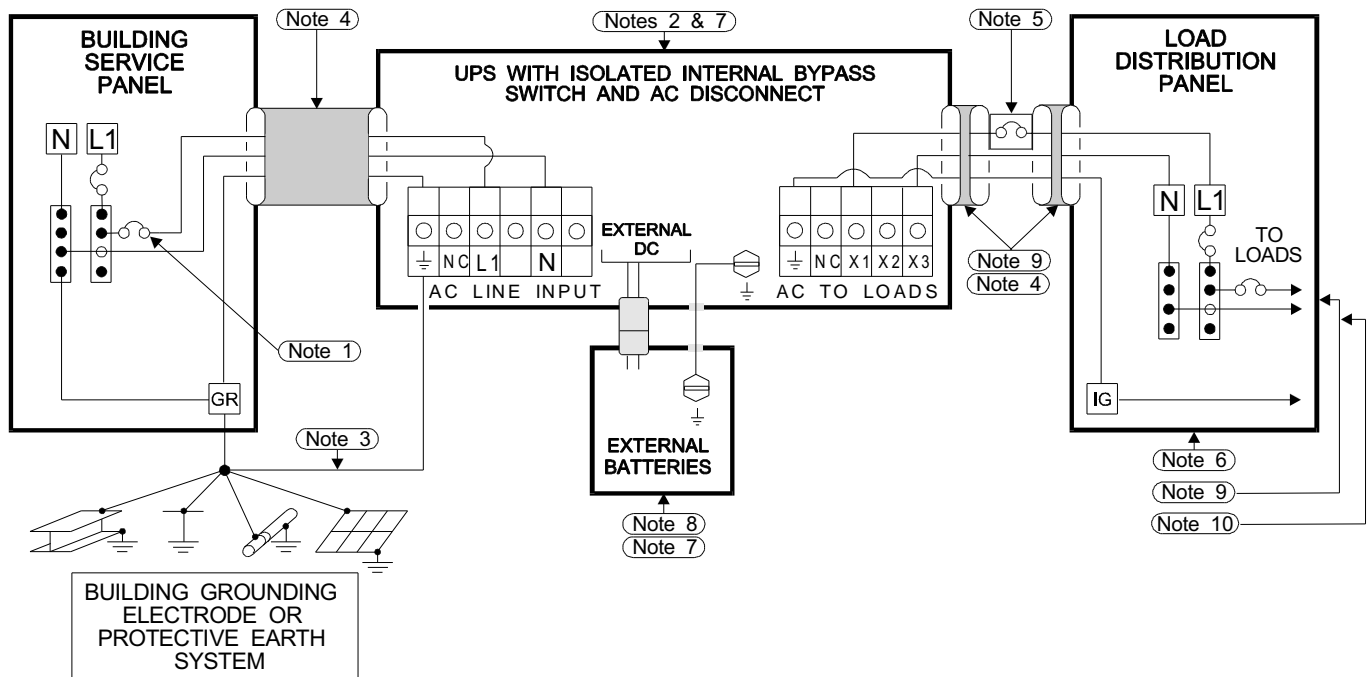

NOTE 1: The customer must provide input overcurrent protection as stated in NEC Section 240-21 or local codes. Size the protection device according to local code requirements. (See [Tables 9 and 10](#) on page 10.)

NOTE 2: The UPS bypass switch must be installed within sight of the UPS. To properly install, complete the voltage and phase check procedure in [Section 500](#).

NOTE 3: The customer must provide and install this ground (earth) connection per NEC Sections 250-5(d), 250-26, 250-91 and 250-92, or local code requirements. This grounding electrode conductor must be at least #8 AWG (8.36 mm²) per NEC table 250-94. If the UPS input circuit conductors are larger than #8 AWG (8.36 mm²), Best Power requires the grounding electrode conductor to be the same size (ampacity) as the largest UPS input circuit conductor. See NEC Section 110-3(b). Conduit is not considered an acceptable grounding electrode conductor. Best Power does not recommend routing the grounding electrode conductor through metallic conduit. This conductor may require protection from physical damage according to local code requirements.

NOTE 4: All AC circuit conductors, including the neutral and equipment grounding conductors, must be the same size (ampacity), have the same rating (75° C copper wire), and be sized according to the input circuit breaker. The UPS input and output conductors must be run through separate conduits.

NOTE 5: The customer must provide output overcurrent protection. See NEC Section 240-21 or local requirements. See [Table 12](#) on page 11 for maximum output overcurrent protection device ratings.

NOTE 6: For maximum protection against electrical noise, use isolated ground receptacles. See NEC Section 250-74, Exception #4.

NOTE 7: See [Section 102](#) for installation and service clearances before installing the UPS. Use flexible conduit on the UPS or the external battery cabinet if either must be moved.

NOTE 8: External UPS battery cabinets are optional. See [Section 400](#) for installation instructions.

NOTE 9: UPS output circuits shall be installed in dedicated conduit systems and not shared with other electrical circuits.

NOTE 10: The load fuse or circuit breaker should be sized to match the load current requirements. See [Table 12](#).

Figure 16: Installation Wiring Diagram for 2, 3, 4.5, 6, and 7.5 kVA FERRUPS Models with Internal Bypass Switch (L1, L2, N)

- 208 Input, 120/240 Output
- 60 Hz 220 Input, 220 Output (Mexico)
- 208 Input, 120/208 Output
- 208 Input, 208 Output
- 230 Input, 230 Output
- 220 Input, 220 Output
- 240 Input, 120/240 Output

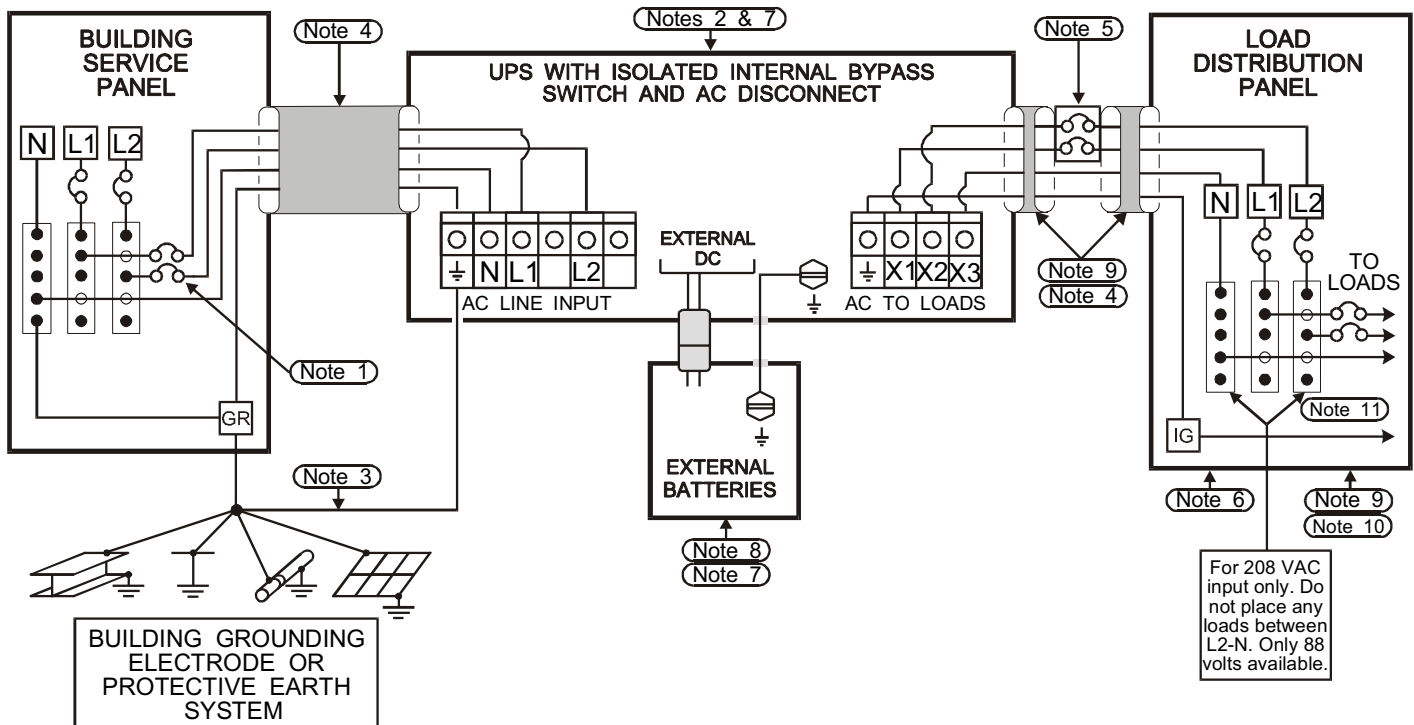

NOTE 1: The customer must provide input overcurrent protection as stated in NEC Section 240-21 or local codes. Size the protection device according to local code requirements. (See [Tables 9 and 10](#) on page 10.)

NOTE 2: The UPS bypass switch must be installed within sight of the UPS. To properly install, complete the voltage and phase check procedure in [Section 500](#).

NOTE 3: The customer must provide and install this ground (earth) connection per NEC Sections 250-5(d), 250-26, 250-91 and 250-92, or local code requirements. This grounding electrode conductor must be at least #8 AWG (8.36 mm²) per NEC table 250-94. If the UPS input circuit conductors are larger than #8 AWG (8.36 mm²), Best Power requires the grounding electrode conductor to be the same size (ampacity) as the largest UPS input circuit conductor. See NEC Section 110-3(b). Conduit is not considered an acceptable grounding electrode conductor. Best Power does not recommend routing the grounding electrode conductor through metallic conduit. This conductor may require protection from physical damage according to local code requirements.

NOTE 4: All AC circuit conductors, including the neutral and equipment grounding conductors, must be the same size (ampacity), have the same rating (75° C copper wire), and be sized according to the input circuit breaker. The UPS input and output conductors must be run through separate conduits.

NOTE 5: The customer must provide output overcurrent protection. See NEC Section 240-21 or local requirements. See [Table 12](#) on page 11 for maximum output overcurrent protection device ratings.

NOTE 6: For maximum protection against electrical noise, use isolated ground receptacles. See NEC Section 250-74, Exception #4.

NOTE 7: See [Section 102](#) for installation and service clearances before installing the UPS. Use flexible conduit on the UPS or the external battery cabinet if either must be moved.

NOTE 8: External UPS battery cabinets are optional. See [Section 400](#) for installation instructions.

NOTE 9: UPS output circuits shall be installed in dedicated conduit systems and not shared with other electrical circuits.

NOTE 10: The load fuse or circuit breaker should be sized to match the load current requirements. See [Table 12](#).

NOTE 11: All 120-volt loads must be connected between N and L1.

Figure 17: Installation Wiring Diagram for 2, 3, 4.5, 6, and 7.5 kVA FERRUPS Models with Internal Bypass Switch (L1, L2, N)

60 Hz 208 or 480 VAC Source with Input Step-Up or Step-Down Isolation Transformer
240 UPS Input - 120/240 UPS Output

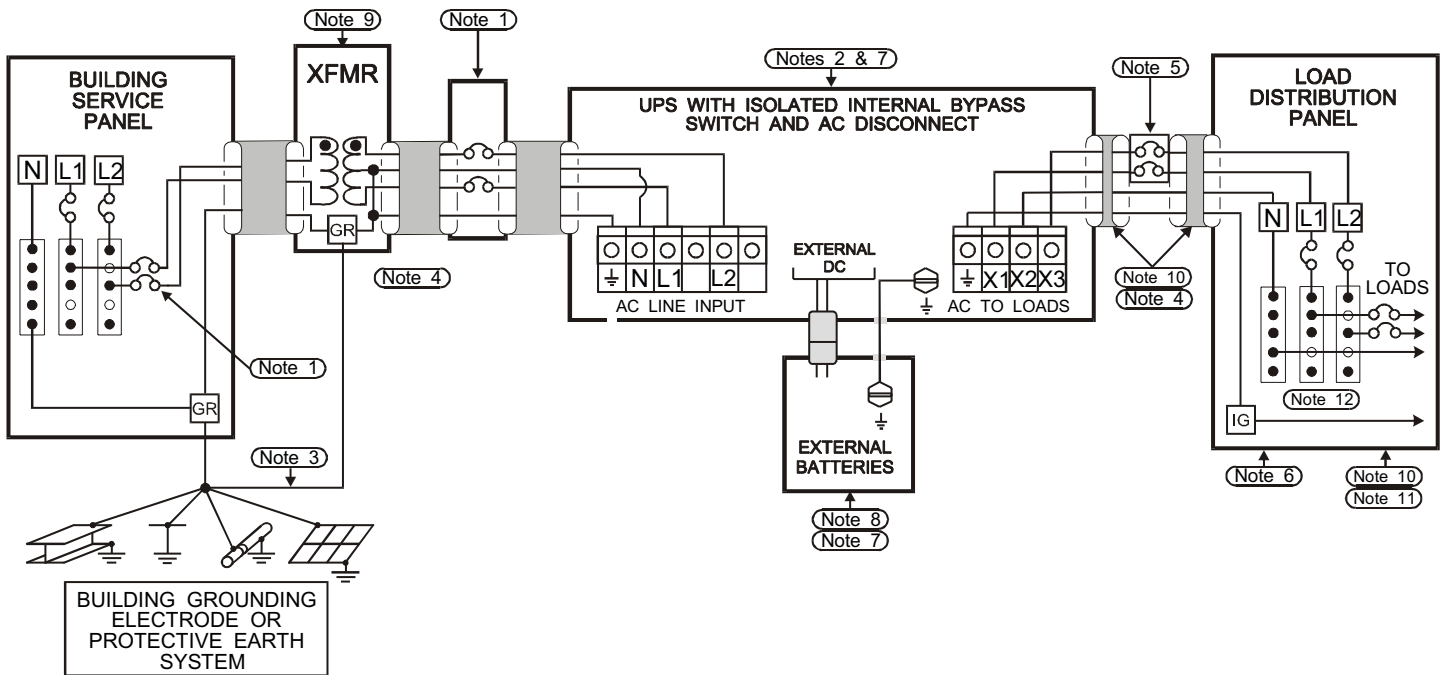

NOTE 1: The customer must provide input overcurrent protection as stated in NEC Section 240-21 or local codes. Size the protection device according to local code requirements. (See [Tables 9 and 10](#) on page 10.)

NOTE 2: The UPS bypass switch must be installed within sight of the UPS. To properly install, complete the voltage and phase check procedure in [Section 500](#).

NOTE 3: The customer must provide and install this ground (earth) connection per NEC Sections 250-5(d), 250-26, 250-91 and 250-92, or local code requirements. This grounding electrode conductor must be at least #8 AWG (8.36 mm²) per NEC table 250-94. If the UPS input circuit conductors are larger than #8 AWG (8.36 mm²), Best Power requires the grounding electrode conductor to be the same size (ampacity) as the largest UPS input circuit conductor. See NEC Section 110-3(b). Conduit is not considered an acceptable grounding electrode conductor. Best Power does not recommend routing the grounding electrode conductor through metallic conduit. This conductor may require protection from physical damage according to local code requirements.

NOTE 4: All AC circuit conductors, including the neutral and equipment grounding conductors, must be the same size (ampacity), have the same rating (75° C copper wire), and be sized according to the input circuit breaker. The UPS input and output conductors must be run through separate conduits.

NOTE 5: The customer must provide output overcurrent protection. See NEC Section 240-21 or local requirements. See [Table 12](#) on page 11 for maximum output overcurrent protection device ratings.

NOTE 6: For maximum protection against electrical noise, use isolated ground receptacles. See NEC Section 250-74, Exception #4.

NOTE 7: See [Section 102](#) for installation and service clearances before installing the UPS. Use flexible conduit on the UPS or the external battery cabinet if either must be moved.

NOTE 8: External UPS battery cabinets are optional. See [Section 400](#) for installation instructions.

NOTE 9: For 208 VAC, use a step-up transformer. For 480 VAC, use a step-down transformer. Use an isolation transformer with a 120/240 grounded center-tapped neutral output. *Do not use a buck/boost transformer.*

NOTE 10: UPS output circuits shall be installed in dedicated conduit systems and not shared with other electrical circuits.

NOTE 11: The load fuse or circuit breaker should be sized to match the load current requirements. [Table 12](#).

NOTE 12: All 120-volt loads must be connected between N and L1.

400 Connecting the External Battery Cabinet(s)

401 Important Notices

If battery cabinets will be stored, connect them to the UPS every 90-120 days and run the UPS for at least 8 hours to recharge the batteries. The warranty will be voided if batteries are not recharged.

If you have ordered battery cabinet model FBT20 or FBT30, no batteries are installed in the battery cabinet, and no cables are provided for connecting batteries to each other. When installing batteries, follow all safety precautions for connecting and servicing batteries in Section 403 below, and follow all precautions recommended by the battery manufacturer. **Do not exceed the DC voltage rating of the UPS.**

402 Tools Needed:

- Wire Cutter
- 7/16-in. Nutdriver or Wrench
- Personal Safety Equipment Required by Local Codes
- Phillips Screwdriver
- 1/4-in. Nutdriver or Wrench

403 Safety Information



For Connecting Battery Cabinets:

The battery cabinet's chassis (ground or earth) must be connected to UPS chassis (ground or earth). Ground additional battery cabinets to each other. (See the grounding instructions in this document.) See the *User Manual* for UPS weights and dimensions. Make sure you are prepared for the weights before you unload or move the UPS or battery cabinets. Do not make connections to the RS232 communication port if the UPS is connected to a positive ground battery system. The RS232 ground must be isolated to prevent equipment damage. For assistance, call the nearest Best Power office.

For Servicing or Replacing Batteries:

Full voltage and current are always present at the battery terminals. Keep unauthorized personnel away from batteries. The batteries used in this system can produce dangerous voltages, extremely high currents, and a risk of electric shock. They may cause severe injury if the terminals are shorted together or to ground (earth). Be extremely careful to avoid contacting battery terminals during battery installation. Do not touch uninsulated battery terminals. Tools must be insulated so that they will not short battery terminals. Do not allow a tool to short a battery terminal to another battery terminal or to the cabinet. Do not lay tools or metal parts on top of the batteries. Batteries contain caustic acids and toxic materials and can rupture or leak if mistreated. Released electrolyte is harmful to the skin and eyes. It may be toxic. Wear protective clothing and eye wear. Remove rings and metal wristwatches or other jewelry. Do not carry metal objects in your pockets; these objects could fall into the battery cabinet or UPS. Disconnect battery cabinets from each other before servicing.

A qualified service person who is familiar with battery systems and required precautions must service the batteries. Batteries must be replaced with Best Power battery number BAT-XXXX. Best Power's batteries come with a two-year warranty; using batteries not supplied by Best Power invalidates any Best Power service agreement. To ensure continued superior performance of your UPS and to maintain proper charger operation, replace the batteries in the UPS or battery cabinets with the same number and type of batteries. Replacement batteries should have the same voltage and ampere-hour rating as the original batteries. Any battery used with this UPS shall comply with the applicable requirements for batteries in the standard for emergency lighting and power equipment, UL 924. The installation must conform to national and local codes. For information on battery replacement, call the nearest Best Power office. **BATTERY REPLACEMENT REQUIRES SPECIAL TOOLS AND EQUIPMENT. CALL BEST POWER BEFORE REPLACING BATTERIES.**

Dispose of batteries properly. Assume that old batteries are fully charged. Use the same precautions you would use when handling a new battery. Do not dispose of battery or batteries in a fire. The battery may explode. Batteries contain lead. Many state and local governments have regulations for disposing of batteries.

Do You Need to Remove Ground from the Battery Terminal? If local or national code requires grounding either battery terminal, remove the connection from the terminal to ground (earth) before servicing the batteries. If any battery terminal is inadvertently grounded, remove the source of ground. Contacting any part of a grounded battery can cause a risk of electric shock. Electric shock is less likely if you disconnect the ground connection before servicing batteries.

404 Connecting the Battery Cabinet(s)

Note: These steps are for connecting battery cabinets. When the batteries need replacement, you will need special equipment and instructions. Call the nearest Best Power office for more information.

1. Make sure the UPS is shut down. If the UPS has a power cord and plug, make sure the UPS has been plugged in to establish a ground connection. If the UPS does not have a power cord and plug, the UPS should be installed according to the instructions in [Section 300](#) of this manual.

2. Place the battery cabinet(s) next to the UPS. Leave at least 12 inches (305 mm) space behind and on the sides of the battery cabinets for ventilation, and leave 36 inches (910 mm) space at the front and top. Leave 12 inches (305 mm) space between the battery cabinet and the UPS.

3. The green ground cable is tie-wrapped with the DC cables on the back of the UPS. Use a wire cutter to cut the section of tie-wrap that is threaded through the ring connector as shown in [Figure 18](#). **DO NOT cut the cables or any of the other tie-wraps!**

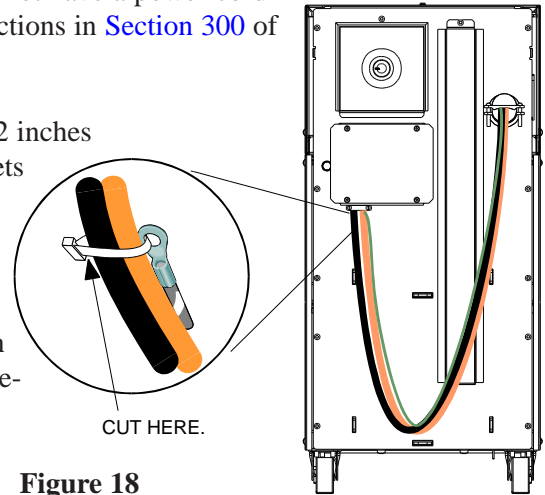

Figure 18

4. Remove the bolt that is labeled with the ground symbol from the back of the UPS. Then, put this bolt into the ring connector at the end of the battery cabinet's green ground cable. Use this bolt to attach the ground cable to the UPS as shown in [Figure 19](#) (or [Figure 20](#) for units with attached bypass switches).

5. Remove the two screws holding the metal plate on the back of the UPS. (See [Figure 19](#); if your UPS has a bypass switch attached, see [Figure 20](#).) Keep the screws for use later.

6. Pull the DC box out of the battery pack as shown in [Figure 19](#) (or [Figure 20](#) for units with attached bypass switches). Remove the packing material from behind the box.

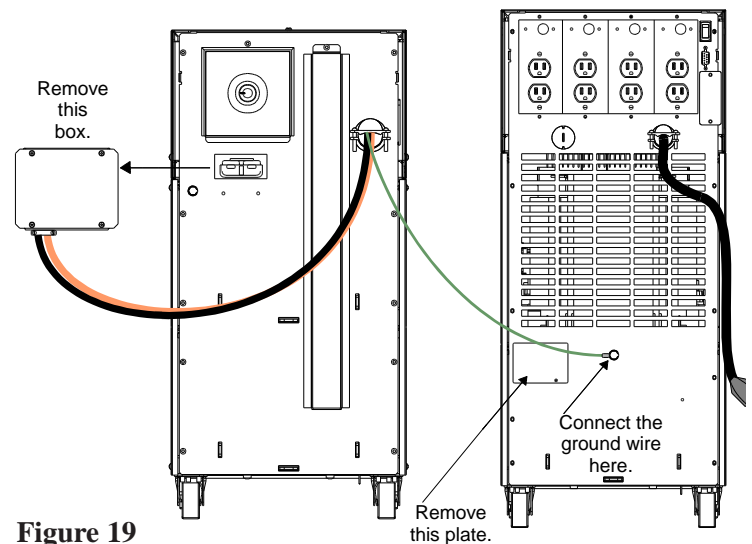

Figure 19

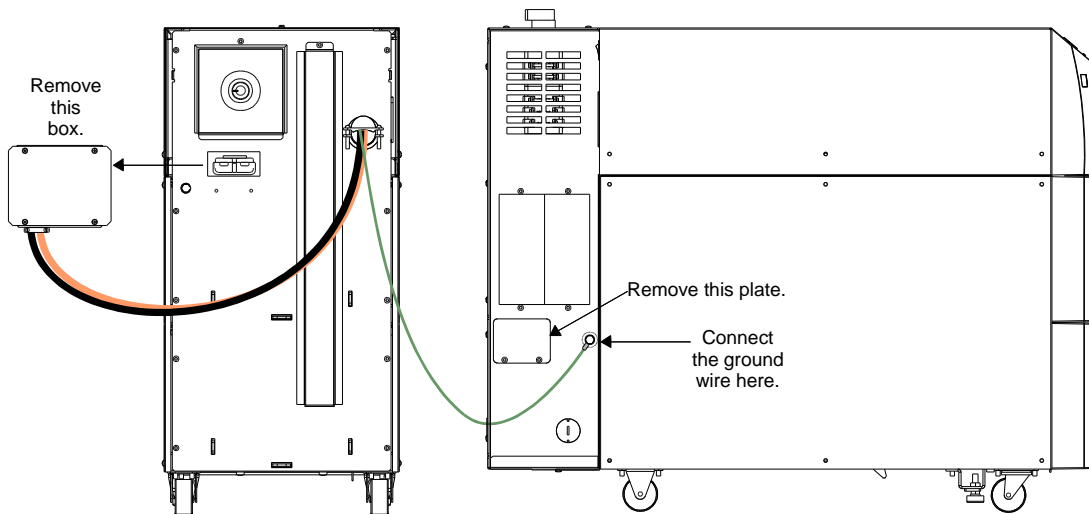

Figure 20

7. Insert the DC box into the back of the UPS as shown in Figure 21, if your UPS has a bypass switch attached, see Figure 22.

If your UPS has more than one battery cabinet, skip step 8 below and go to step 9.

8. *If your UPS has only one battery cabinet*, attach the metal plate (removed from the UPS) to the back of the battery cabinet as shown in Figure 21 or 22. Use the two screws you removed from the UPS in [step 5](#). You are now finished connecting the cables. Skip the steps below and go to [Section 405](#).

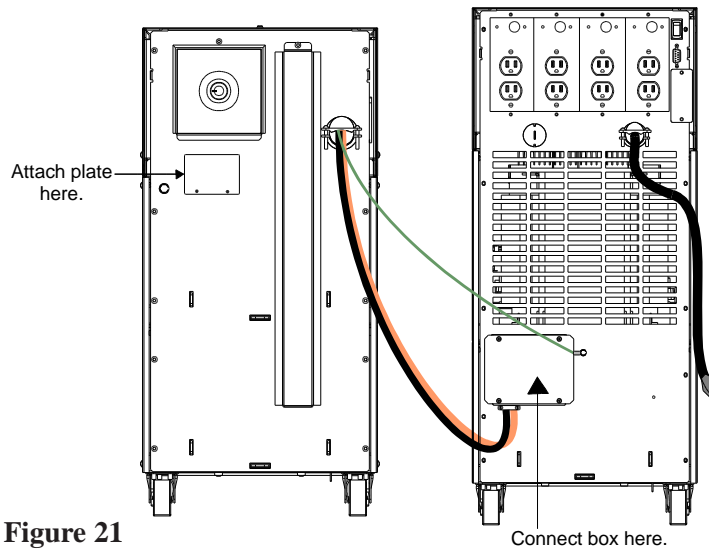

Figure 21

9. *If your UPS has more than one battery cabinet*, put the DC box from the second battery cabinet into the connector on the back of the first battery cabinet as shown in Figure 23.

10. Put the DC box from the third battery cabinet into the connector on the back of the second battery cabinet as shown in Figure 23.

11. At the third battery cabinet, attach the metal plate you removed from the UPS to the back of the battery cabinet as shown in Figure 23. Use the screws that attached the plate to the UPS.

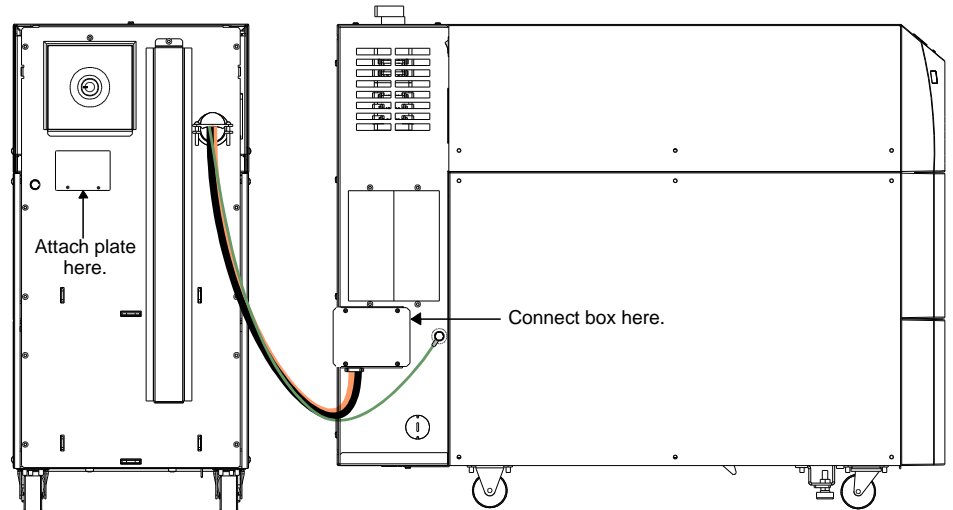

Figure 22

You have finished connecting the battery cabinets. Now, go on to [Section 405](#) to turn on the DC switch.

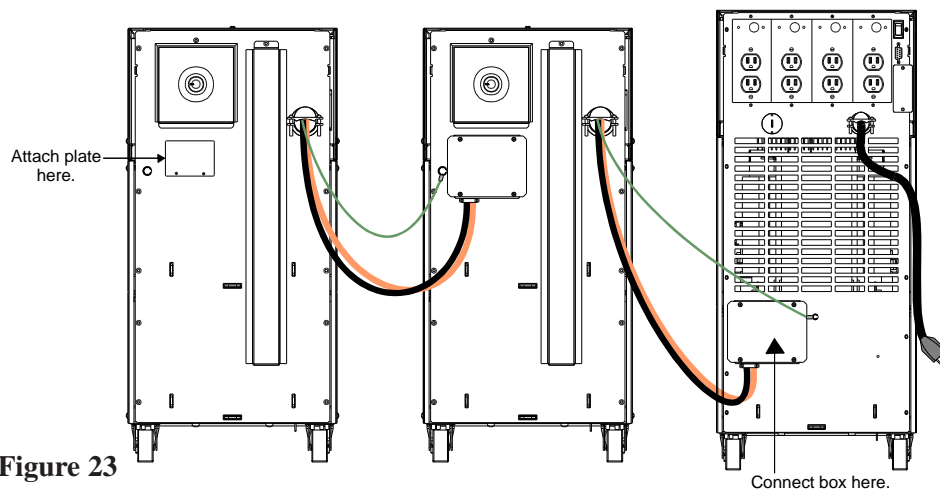

Figure 23

405 Turning the DC Switch On and Off

1. At the back of the battery cabinet, insert the key into the switch, and turn the key all the way to the right (clockwise).
2. Pull the red knob out (toward you). You can then remove the key from the switch.

When you need to turn the DC switch off, simply push the red knob in. The key is not needed.

Important: Go to Section 500 to program the battery parameters. If your UPS does not have a line cord and plug, you must also perform the phase check in Section 500.

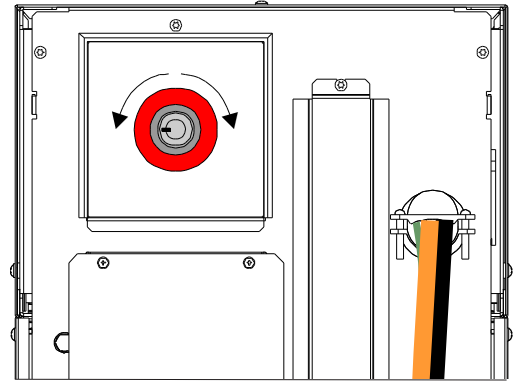

Figure 24

500 Parameters and Phase Check (for Qualified Personnel Only)

This section explains how to start the UPS, program parameters that need to be set after installation, and perform a voltage and phase check. (The voltage and phase check is only for units without line cords and plugs.)

Starting the UPS

1. Make sure that the main circuit breaker in the load service panel is off, or make sure the loads cannot receive power from the UPS. Make sure that the bypass switch is in the OFF position.
2. At the UPS AC input service panel, turn on the input power to the UPS and the bypass switch. The green light that is next to the UPS display panel will light.
3. Turn on the DC switch at each battery cabinet (see [Section 405](#) above).
4. At the UPS back panel, press and hold the On/Off switch until the UPS starts.
5. At the bypass switch, press the red button and turn the switch to “UPS.”

Parameter Settings

6. This step is only necessary if your UPS has separate battery cabinets. If not, go on to step 7.

When you connect battery cabinets to the UPS, you must change the value of some UPS parameters so the UPS is programmed for its new battery capacity.

- a. First, you must switch from the standard display (showing the UPS mode and the % load) to the menu display. To do this, press the bottom right button (below “Menu” on the display). The display will show “1 Enter password.”
- b. You must enter the User password before programming the output voltage parameter. Press ↵. A blinking cursor will appear in the password setting under the first digit.
- c. The User password is 377; this means that you must change the display to “0377.” To do this, first press the middle button below “->” on the display once to scroll to the second digit. Then, press ▲ three times to increase the value of this digit to “3.”

Continue to use the ← and → buttons to move to the digits that you need to change, and use the ▲ and ▼ buttons to increase or decrease the value of each digit. When the display shows “0377,” press ↵ to save the new setting. “User” will appear at the top of the display to show that you have entered the User password.

- d. Press ▼ three times until the display shows “4 System ID.” Then, press ↵. The display will now show “4 1 Model Number.” Press ▼ five times; the display will show “4 6 Batt Amp Hours.”
- e. Now, check the information on the invoice shipped with your UPS to determine what battery cabinet and batteries your UPS has. Then, use this information to find the correct ampere-hour rating in Table 13.

Table 13: Battery Ampere-Hour Settings

| Battery Cabinet Number: | Batteries in UPS: | Batteries in Battery Cabinet(s) | Battery Ampere-hour Rating by UPS Model | | | | | |
|-------------------------|----------------------------------|---------------------------------|---|----------------------|-------|---------|-------|---------|
| | | | 2 kVA (standard) | 2 kVA (ext. runtime) | 3 kVA | 4.5 kVA | 6 kVA | 7.5 kVA |
| FBT20 | (4) BAT-0053 or (4) BAT-0058* | None** | Add the ampere-hour ratings of each string in the battery cabinet and the battery string in the UPS to determine the parameter setting. | | | | | |
| FBT21 | (4) BAT-0053 or (4) BAT-0058* | (4) BAT-0053 | 48 | 62 | 62 | 62 | | |
| FBT22 | (4) BAT-0053 | (8) BAT-0053 | 79 | 93 | 93 | 93 | | |
| FBT30 | (4) BAT-0053 | None** | Add the ampere-hour ratings of each string in the battery cabinet and the battery string in the UPS to determine the parameter setting. | | | | | |
| FBT31 | (4) BAT-0053 | (4) BAT-0483 | 92 | 106 | 106 | 106 | 150 | 150 |
| FBT32 | (4) BAT-0053 | (8) BAT-0483 | 167 | 181 | 181 | 181 | 225 | 225 |
| FBT31 + FBT32 | (4) BAT-0053 | (12) BAT-0483 | 242 | 256 | 256 | 256 | 300 | 300 |
| Two FBT32 | (4) BAT-0053 | (16) BAT-0483 | 317 | 331 | 331 | 331 | 375 | 375 |
| FBT31 + Two FBT32 | (4) BAT-0053 | (20) BAT-0483 | 392 | 406 | 406 | 406 | 450 | 450 |
| Three FBT32 | (4) BAT-0053 | (24) BAT-0483 | 467 | 481 | 481 | 481 | 525 | 525 |

* Standard 2 kVA units have (4) BAT-0058 batteries. 2 kVA units with the internal extended runtime option have (4) BAT-0053 batteries. Your unit’s invoice should identify the batteries inside the UPS.

** FBT20 and FBT30 battery cabinets do not come with batteries installed. No cables are provided for connecting batteries to each other.

- f. Press ↵. A blinking cursor will appear under the first digit in the setting (value) of this parameter. Notice that the bottom row of the display changes to “← → ESC” to show you the functions of the buttons below the display. Use the ▲ and ▼ buttons to increase or decrease this digit as needed. Then, use the button below → to move to remaining digits, and use the ▲ and ▼ buttons to change the value of each digit. When the display shows the correct battery ampere-hour rating, press ↵ to save the setting.
7. This step is only necessary if your UPS does **not** have an input line cord and plug. In order for the FERRUPS to provide the desired output voltage(s), you must program the Nominal AC Volts Out parameter. To do this, follow these steps:
 - a. Use Table 14 to determine the proper setting for the Nominal AC Volts Out parameter.

Table 14: Nominal AC Volts Out Settings

| If you have wired the UPS for this output voltage... | ...set parameter 4 8 (Nominal AC Volts Out) to this: |
|--|--|
| 220 | 220 |
| 230 | 230 |
| 120 and/or 240 | 240 |
| 208 or 120/208 | 208 |
| 127 and/or 220 | 254 |

- b. If the display is showing information about the system mode and % load, press the bottom right button (below “Menu”) to switch to the menu display. The display will show “1 Enter password.”

If the display is already showing the menus, go to step c.

- c. *If the word “User” is in the upper right corner of the display*, the User password has already been entered; go to step d.

If not, you must enter the User password. First, press the bottom right button (below the word “ESC”) until there is only one number (one digit) on the top line of the display. Then, press the bottom middle button (below the word “Top”). The display should show “1 Enter password.” The User password is 0377; this means that you must change the display to “0377.” To do this, first press the middle button below “->” on the display twice to scroll to the second digit. Then, press ▲ three times to increase the value of this digit to “3.” Continue to use the <- and -> buttons to move to the digits that you need to change, and use the ▲ and ▼ buttons to increase or decrease the value of each digit. When the display shows “0377,” press ↵ to save the new setting. “User” will appear at the top of the display to show that you have entered the User password.

- d. *If your display is already showing parameter 4 6 (Batt Amp Hours)*, press ▼ twice to scroll down to parameter 4 8 (Nominal AC V Out).

If the display is showing “1 Enter password,” press t three times. The display should show “4 System ID.” Press ⏏; then, press ▼ seven times. The display should now show “4 8 Nominal AC V Out.”

- e. Press ↵. A blinking cursor will appear in the setting for AC volts out. Notice that the bottom row of the display changes to “<- -> ESC” to show you the functions of the buttons below the display. Use the <- and -> buttons to move to the digits that you need to change in the display, and use the ▲ and ▼ buttons to increase or decrease the value of each digit. When the digits show the setting you need, press ↵ to save the new setting.

Phase Check

If your UPS has a line cord and plug, skip the steps below, turn the FERRUPS off, and push in the DC switch at each battery cabinet. You have finished installing the FERRUPS. See the User Manual for more information.

If your UPS does not have a line cord and plug, you must follow the steps below to complete the voltage and phase check.

Note: **If your UPS has separate battery cabinets, make sure you connect the cabinets as described in Section 400 before you perform the voltage and phase check.**

 **CAUTION**

Before you switch the bypass switch, follow the steps below to check for correct operation. To prevent damage to the loads, make sure the main circuit breaker in the load service panel is off, or make sure the protected equipment (loads) cannot receive power from the UPS.

8. At the bypass switch, make sure the voltage from the UPS to the loads is close to the voltage from AC line to the bypass switch. (There may be slight differences.) At the bypass switch terminal strip, find the measurement points listed below for your bypass switch type. Use an AC voltmeter to measure the voltage between these points. Record your voltage measurements in the spaces provided below. The voltages in the first column should be similar to the values in the second column. **If the difference is more than a few volts, check the connections at the terminal strip and correct any wiring problems.** If you need help, call [Best Power's Worldwide Service or the nearest Best Power office](#).

External Bypass Switch:

| <u>AC Line Input</u> | <u>AC from UPS Output</u> |
|----------------------------|---------------------------|
| L1 to L2 (11 to 12*) _____ | 7 to 8* _____ |
| N to L1 (10 to 11*) _____ | 6 to 7* _____ |
| N to L2 (10 to 12*) _____ | 6 to 8* _____ |

**For some installations, there is no connection at terminals 6, 10, 8, or 12.*

Internal Bypass Switch:

| <u>AC Line Input</u> | <u>AC from UPS Output</u> |
|----------------------|---------------------------|
| L1 to L2 _____ | X1 to X2 _____ |
| N to L1 _____ | X3 to X1 _____ |
| N to L2 _____ | X3 to X2 _____ |

9. If you have a Break-Before-Make (BBM) bypass switch, go to step 10.

If you have a Make-Before-Break (MBB) bypass switch, make sure the AC voltages from the UPS output and the AC line input are in phase. To do this, measure the voltage between the following points on the bypass switch terminal strip. **These measurements must not be more than 100 VAC; if they are, call Best Power's [Worldwide Service or the nearest Best Power office](#).**

External Bypass Switches: 7 to 11 _____
8 to 12 _____

Internal Bypass Switches: UPS terminal L1 to Internal Bypass terminal L1 _____
UPS terminal L2 to Internal Bypass terminal L2 _____

10. Measure the AC voltage between the following points on the bypass switch terminal strip. **This reading must not be more than 1 VAC. If it is, call [Best Power's Worldwide Service or the nearest Best Power office](#).**

External Bypass Switches: 6 to 10 _____

11. Now switch the bypass switch to “LINE.” Using the AC voltmeter, make sure that the voltage to your protected equipment is correct; you can verify the voltage at the Load Distribution Panel or the UPS-protected receptacles for your equipment.
12. Next, switch the bypass switch to “UPS” and verify the voltage to your protected equipment once more.
13. If all of your readings in the voltage and phase check are acceptable, follow these steps:
 - a. Put the bypass switch cover back on and tighten the screws securely.
 - b. Turn the FERRUPS off.
 - c. Push in the DC switch at each separate battery cabinet to turn off DC.
 - d. Put the top cover back on the UPS, and reattach all screws. (There are three screws on each side, and there is one screw on the top.) After you have reattached the top cover, push the front panel back in place.
 - e. Turn of the AC LINE Disconnect switch. If you will not be starting the UPS now, you can leave the bypass switch in the “LINE” position and switch on your protected equipment. Your equipment will be receiving direct AC input power; it will not be protected until you start the UPS and switch the bypass switch to “UPS.”

You have finished installing the FERRUPS. To restart the UPS, see the User Manual.

Appendix A: Connections for the Emergency Power Off (EPO) Signal

Computer rooms often have an emergency shutdown switch (or panic button) that shuts off the power to all equipment in the computer room. If the UPS’ AC input source is connected to the switch, the switch will shut off the FERRUPS input power. However, the UPS will interpret this as a power outage and will continue to provide **output** power to the equipment it protects until its batteries run down. To make sure the emergency shutdown switch can shut off the UPS’ **output** power, use the unit’s remote Emergency Power Off (EPO) feature.

Your computer room’s emergency shutdown switch must have a set of **dedicated** contacts that can short pin 1 of J13 to pin 2. Use a shielded, single twisted pair cable to connect the emergency shutdown switch to the UPS. See [Figure 26](#). When pin 1 is shorted to pin 2, the FERRUPS output power is shut off. When this happens, the FERRUPS will display an “EPO Shutdown” alarm. To restart the UPS after a shutdown, press the On/Off switch on the UPS back panel, and press a button on the front display panel to confirm the restart.

If your unit has an external (separate) bypass switch, you must also connect wires from the bypass switch to J13 on the UPS logic board. (See Figure 26 on the next page.) It is best to make this connection at the same time that you connect the bypass wires to J13 (see [step 8 in Section 302](#)). To make the connection, follow the steps on the next page.

1. If the top cover has not already been removed, first pull the top front panel out slightly; the holes in the right side of the panel can help you do this. **Do not strain the ribbon cable behind this panel.** If you need to remove the front panel completely, you can disconnect the ribbon cable first, but the display will not operate until you reconnect it. Remove the three screws on each side of the UPS and one screw on top of the UPS as shown on the next page. Then, lift the cover off the UPS.

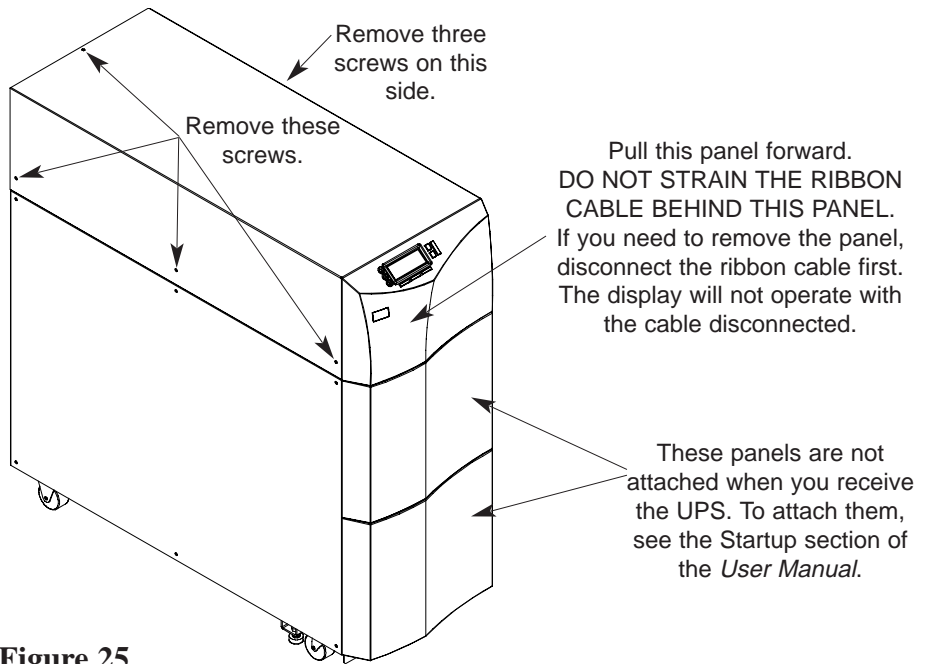

Figure 25

2. Route the EPO cable through the grommet shown in Figure 26 and to connector J13 on the logic board.
3. Pull the 8-pin connector at J13 apart as shown in Figure 26. The portion you remove from the connector has 8 possible connection points.
4. Loosen the standard screws shown in Figure 26.
5. Connect the twisted pair in the EPO cable to pins 1 and 2 of connector J13. Note that pin 2 is common (signal ground). *If you are also connecting wires from the external bypass switch, go back to Section 302, step 8f.*
6. Tighten the screws to secure the connections (torque specification is 2.61 inch-pounds/0.3 N-m), and reattach the connector to J13 on the logic board.
7. Use the tie-wraps provided to secure the cable. See Figure 26.
8. Place the top cover back on the UPS, and use the screws you removed to reattach the cover. Then, push the front panel back in place.

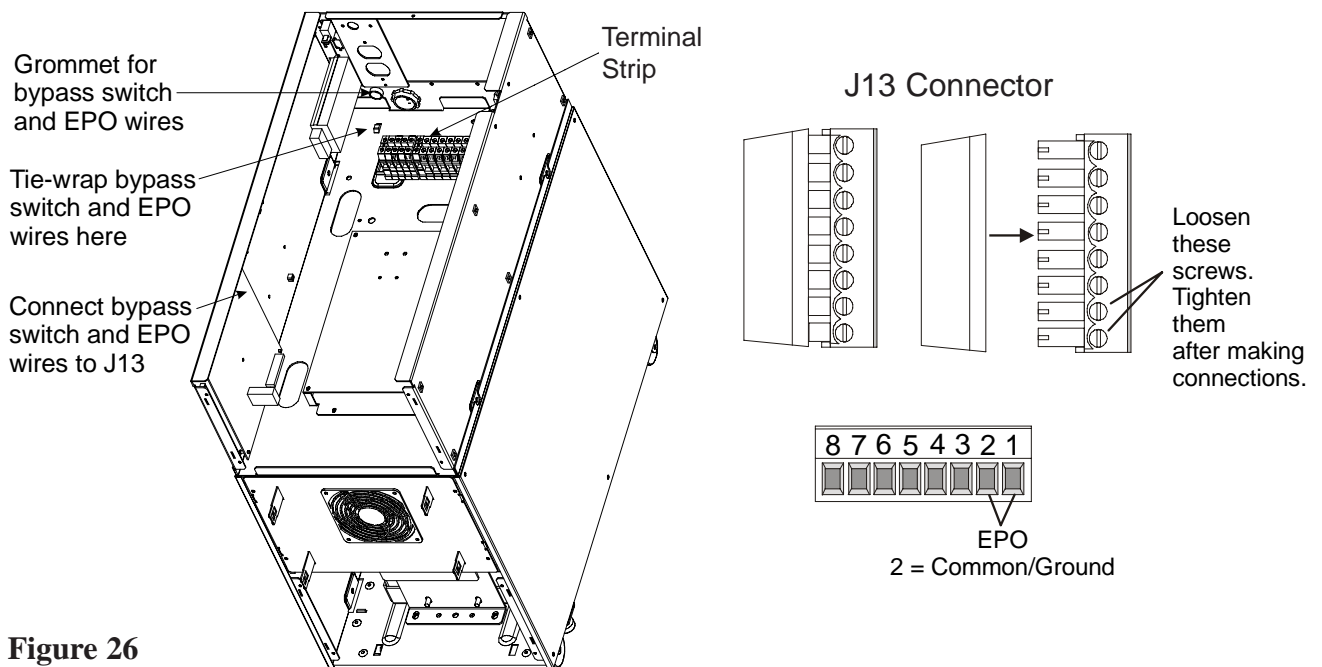

Figure 26